

**EPSON®**

**LQ-2500  
USER'S MANUAL**

**X-LQ2500**

---

**EPSON®**  
**LQ-2500**

User's Manual

---

## FCC COMPLIANCE STATEMENT FOR AMERICAN USERS

---

This equipment generates and uses radio frequency energy and if not installed and used properly, that is, in strict accordance with the manufacturers instructions, may cause interference to radio and television reception. It has been type tested and found to comply with the limits for a Class B computing device in accordance with the specifications in Subpart J of part 15 of FCC Rules, which are designed to provide reasonable protection against such interference in a residential installation. However, there is no guarantee that interference will not occur in a particular installation. If this equipment does cause interference to radio or television reception, which can be determined by turning the equipment off and on, the user is encouraged to try to correct the Interference by one or more of the following measures:

- Reorient the receiving antenna
- Relocate the printer with respect to the receiver
- Plug the printer into a different outlet so that the printer and receiver are on different branch circuits.

If necessary, the user should consult the dealer or an experienced radio/television technician for additional suggestions. The user may find the following booklet prepared by the Federal Communications Commission helpful:

"How to Identify and Resolve Radio-TV Interference Problems."

This booklet is available from the U.S. Government Printing Office, Washington, DC 20402. Stock No. 004-000-003454.

### WARNING

The connection of a non-shielded printer interface cable to this printer will invalidate the FCC Certification of this device and may cause interference levels which exceed the limits established by the FCC for this equipment. If this equipment has more than one interface connector, do not leave cables connected to unused interfaces.

All rights reserved. No part of this publication may be reproduced, stored in a retrieval system, or transmitted, in any form or by any means, mechanical, photocopying, recording or otherwise, without the prior written permission of Seiko Epson Corporation. No patent liability is assumed with respect to the use of the information contained herein. While every precaution has been taken in the preparation of this book, Seiko Epson Corporation *assumes no* responsibility for errors or omissions. Neither is any liability assumed for damages resulting from the use of the information contained herein.

Apple is a registered trademark of Apple Computer, Inc.

Centronics is a registered trademark of Centronics Data Computer Corporation.

Epson is a registered trademark of Seiko Epson Corporation.

ESC/P is a trademark of Seiko Epson Corporation.

IBM is a registered trademark of International Business Machines Corporation.

Microsoft is a trademark of Microsoft Corporation.

Copyright © 1986 by Seiko Epson Corporation  
Nagano, Japan

---

# Contents

---

## Introduction

## Setting Up Your Printer

---

### Chapter 1

#### Setting Up the Printer

- 1-1 Unpacking the Printer
- 1-3 Choosing a Place for the Printer
- 1-3 Installing the Ribbon
- 1-5 Turning On the Printer
- 1-6 Operating the Control Panel
- 1-9 Installing the Paper Guide
- 1-10 Loading Paper
- 1-13 Running the Self Test
- 1-15 Connecting the Printer to Your Computer
- 1-16 A Final Checklist

## SelecType

---

### Chapter 2

#### SelecType

- 2-1 The SelecType Panel
- 2-2 Entering SelecType
- 2-3 The SelecType Main Menu
- 2-4 \*LOAD MACRO
- 2-8 \*CHANGE MACRO
- 2-13 \*CHANGE DEFAULTS
- 2-18 \*PRINT OUT SETTINGS

## Using Your Printer

---

### Chapter 3

#### Choosing and Loading Paper

- 3-1 Choosing Paper
- 3-1 Loading Single Sheets
- 3-2 Loading Continuous-feed Paper
- 3-7 Loading Labels
- 3-8 The Paper Thickness Lever

---

## Chapter 4

---

### **Using the LQ-2500 with Application Programs**

- 4-2 Choosing the Correct Printer
- 4-2 Computer- Printer Communication
- 4-3 Setting Up Application Programs
- 4-4 Word Processors
- 4-7 Spreadsheets
- 4-10 Setting Up Graphics Programs
- 4-11 Programming Languages

---

## Chapter 5

---

### **Using the LQ-2500 Print Features**

- 5-1 Print Quality
- 5-2 Selecting Fonts
- 5-4 Print Pitch and Character Width
- 5-7 Using Character Tables and Sets

---

## Chapter 6

---

### **Graphics and User-defined Characters**

- 6-2 The Print Head
- 6-4 Graphics Commands
- 6-11 User-defined Characters
- 6-13 Defining Your Own Characters
- 6-17 Printing User-defined Characters

## **Command Summary**

---

### Appendix A

---

#### **Command Summary**

- A-4 Commands in Numerical Order
- A-7 Epson (ESC/P) Commands

---

## Reference

### Appendix B

---

#### **ASCII Conversion Chart and Character Tables**

- B1 ASCII Conversion Chart
- B-3 International Character Sets-Draft
- B-3 international Character Sets-Letter Quality
- B-4 How to Use the Charts
- B-5 Epson Italics Character Set-Draft
- B-5 Epson Italics Character Set-Letter Quality
- B-6 Epson Graphics Character Set-Draft
- B-6 Epson Graphics Character Set-Letter Quality
- B-7 Epson Graphics Character Set
- B-8 Proportional Width Tables

### Appendix C

---

#### **Typestyle Summary**

- C-3 Epson Draft
- C-3 Selecting Typestyles with Master Select

### Appendix D

---

#### **Problem Solving and Maintenance**

- D-1 General Troubleshooting
- D-4 Troubleshooting Graphics Problems
- D-5 Troubleshooting for Serial Interface Communications
- D-5 Hex Dump Mode
- D-7 Solutions for IBM **and** Compatibles
- D-7 IBM BASIC Solutions
- D-7 Maintaining Your Printer
- D-8 Transporting the Printer

### Appendix E

---

#### **Initialization and Default Settings**

---

## Appendix F

---

### **Choosing and Setting Up Optional Interfaces**

- F-1 Compatible Interfaces
- F-2 Choosing an Interface
- F-4 Installing an Interface
- F-6 Inserting the Interface Board
- F-7 Serial Interface Settings

---

## Appendix G

---

### **Technical Specifications**

- G-1 Printing
- G-2 Paper
- G-2 Mechanical
- G-3 Electrical
- G-3 Environment

---

## Appendix H

---

### **Interface Specifications**

- H-1 The Parallel interface
- H-3 The Serial Interface

---

## Glossary

---

---

## Index

---

---

## Introduction

The Epson LQ-2500 introduces a new concept in dot matrix printing. In addition to the speed and sharpness of a 24-pin, dot matrix printer, the LQ now has SelecType with a Liquid Crystal Display SelecType lets you control your printing with a touch of a button, and the LCD tells you what's happening. You can even create your own macros to save your most-used printer settings.

The LQ-2500 has five *built-in* Letter Quality fonts *to* choose from, so you don't have to buy extra cartridges or options. The LQ is also capable of a wide variety of print enhancements, including:

| LETTER QUALITY                 | DRAFT                   |
|--------------------------------|-------------------------|
| Bold                           | Bold                    |
| Italic                         | Italic                  |
| <u>Underlining</u>             | Underlinging            |
| <b>Subscript</b>               | <b>Subscript</b>        |
| Superscript                    | Superscript             |
| <b>D o u b l e - w i d t h</b> | D o u b l e - w i d t h |

The LQ-2500 combines the versatility and reliability of Epson products with a wide range of exciting features:

- You can control all printing operations from the control panel with SelecType, *and* know what's happening by reading the LCD.
- There are four preset macros you can use, or you can create your own.
- You can select either draft or Letter Quality or one of the five built-in fonts, with a touch of a control panel button.
- There are two built-in paper feeding systems: An automatic single-sheet loading method, and an easy-to-load push tractor unit.
- The LQ has built-in parallel and serial interfaces, so there's no need for extra options or modifications.
- The Color Option kit transforms the LQ-2500 into a seven-color printer, for finely detailed color printing.



---

## Using this manual

To make it easier to set up your new LQ-2500, this manual includes a 10-step guide to setting up your printer. The outline on the **back** cover flap, and the numbered steps in the chapter take you from unpacking, through ribbon and paper loading, to a final printing checklist.

Five easy-to-find section dividers in the manual make it simple for beginners or experienced users to look up information. The five sections are: Setting Up Your Printer, SelecType, Using Your Printer, Command Summary and Reference. There is also a glossary after the appendixes, and a diagram on the Quick Reference card to help you with SelecType.

## Setting Up the Printer

Setting up your LQ-2500 printer is easy. Simply follow the steps in this chapter.

### 1 Unpacking the Printer

As you unpack the printer, make sure the box contains all of the parts shown in Figure 1-1. Check that none of the parts have been damaged during transportation. (you'll find the paper feed knob inserted in the foam packing material.)

#### Caution

Do not plug in the power **cord** yet. You should perform the first three steps before you plug in the printer and turn on the power.

Remove the tape that holds the dust cover in place during shipping and take the cover off the printer. Simply tilt the dust cover up and lift it off.

Figure 1-1.  
The printer parts

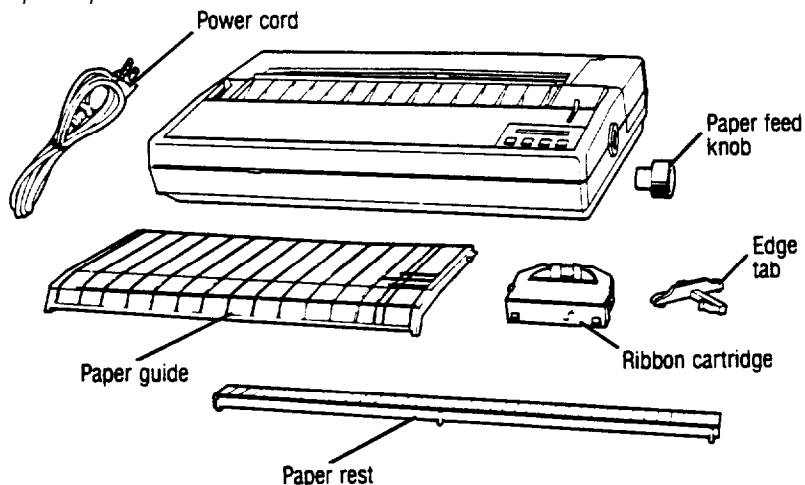

---

## Installing the paper feed knob

Install the paper feed knob on the right side of the printer, as shown in Figure 1-2. Line up the flat side of the hole in the knob with the flat side of the shaft, then push the knob firmly into place.

Now, that you've installed the paper feed knob, use it to remove the sheet of paper that is behind the printer's platen (the black roller).

## Removing the print head protector

Remove the print head protector by opening the paper bail, then lifting the protector up and pulling it to the right as shown in Figure 1-3 below.

---

*Figure 1-2.*  
*Installing the paper feed knob*

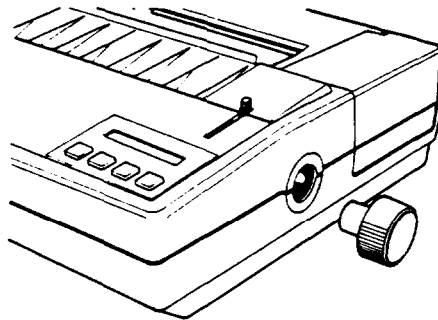

---

*Figure 1-3.*  
*Removing the print head protector*

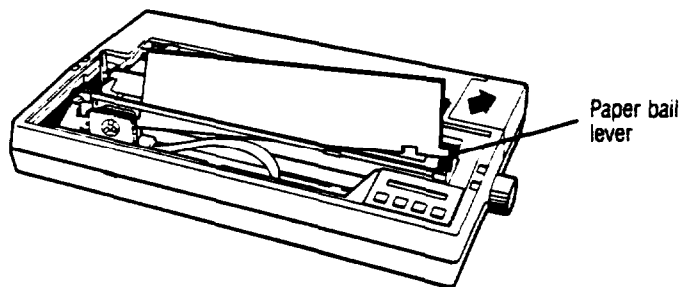

---

When you are finished unpacking, put the packaging materials and the head protector in the box and keep them in case you need to transport the printer. Full details on transporting the printer are in Appendix D.

---

## **2 Choosing a Place for the Printer**

The printer must be close enough to the computer for the cable to reach. Also keep the following tips in mind:

- Place the printer on a flat, stable surface—never on a chair or any other unstable support.
- Choose a place that is clean and free from excessive heat (including direct sunlight), moisture, and dust.
- Use a grounded outlet—one that has three holes to match the power plug on the printer. Don't use an adapter plug.
- Avoid sockets on the same circuit with large motors or other appliances that might disturb the power supply.
- Keep your entire computer system away from potential sources of interference such as the base units of cordless telephones.

---

## **3 Installing the Ribbon**

The LQ-2500 uses a simple cartridge ribbon for convenient and troublefree installation. With the color option kit, you can use a color ribbon whenever YOU need one and a normal black ribbon for day-to-day printing. You install both types of ribbon in the same way

1. Remove the dust cover.
2. If the printer is plugged in, be sure that it's turned off.

---

## WARNING

The power must be OFF when you move the print head. Otherwise, you may damage the printer mechanism. Also, if you've been using the printer just before changing the ribbon cartridge, be careful not to touch the print head because it becomes hot during use.

---

3. Move the print head carriage to about 25 on the ruler on the paper bail.
4. Remove the ribbon cartridge from its packaging and tighten the ribbon by turning the knob in the direction of the arrow, as shown in Figure 14.
5. Make sure the paper bail is against the platen.
6. Hold the cartridge, gently squeezing the two ridged plastic tabs together; then lower it (as shown in Figure 1-5) into the print head carriage. As you lower it, make sure the tab on the back of the cartridge rests on the support ridge on the carriage and that the ribbon passes between the print head and the silver ribbon guide.
7. Release the tabs so that the pins on the tabs click into the holes in the sides of the print head carriage.

---

*Figure 1-4.*  
*Tightening the ribbon*

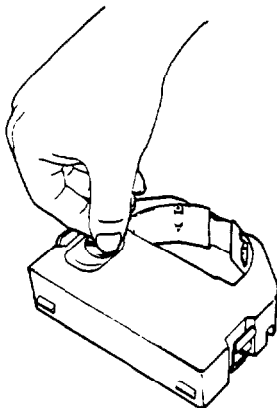

*Figure 1-5.*  
*Installing the ribbon*

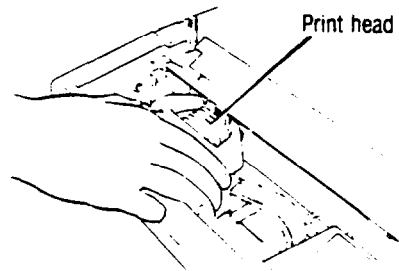

- 
- Turn the ribbon tightening knob again to make sure the ribbon moves freely

### **Replacing the ribbon . . .**

The LQ-2500 uses a continuous-loop, inked fabric ribbon. When your printing becomes too light, replace the whole ribbon cartridge.

Always use replacement ribbons #7756 (black) and #7757 (color) designed specifically for the Epson LQ-2500 printer. It is not possible to use ribbons for any other series of printer, and you should never try to re-ink the ribbon.

To remove the old ribbon, simply grip the cartridge by the two plastic tabs and lift it up and out of the printer. You can then install a new cartridge as previously described.

---

## **4 Turning On the Printer**

Before plugging in the power cord, make sure the power switch on the left side of the printer (see Figure 1-6) is turned off; then plug the power cord into a properly grounded socket.

---

### **WARNING**

Before turning on the printer, be absolutely sure you have removed all packing materials. Turning on the printer when the print head cannot move may seriously damage the mechanism.

---

*Figure 1-6.  
Turning on the printer*

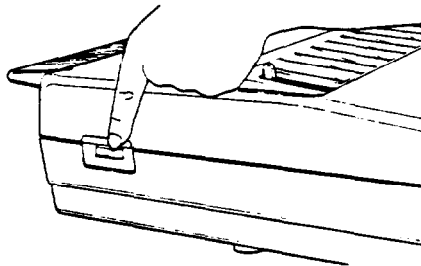

---

Now, turn the power ON. When you turn on the printer, several important things happen:

- The print head moves back and forth and stops at about 40 on the paper bail ruler.
- The ribbon carriage moves up and down to set the ribbon at the correct level for printing.
- The printer is *initialized* and set to certain *default* settings (which are fully described in Chapter 2 and Appendix E).
- The green POWER light on the control panel comes on. The red PAPER **OUT** light also comes on, and the display reads [PAPER OUT].

---

## 5 Operating the Control Panel

The LQ-2500 control panel is made up of three elements: the buttons, indicator lights, and SelecType Liquid Crystal Display (LCD), as shown in Figure 1-7.

---

Figure 1-7  
The control panel

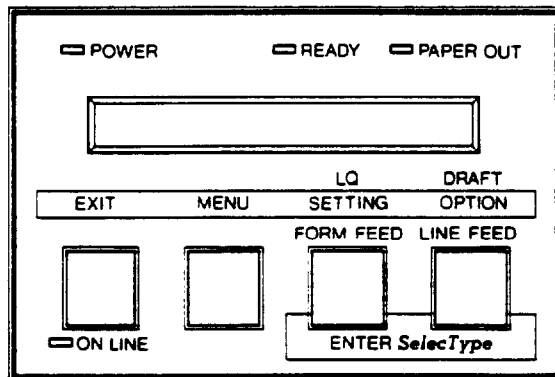

---

From this panel, you can control almost all printer functions. On the LQ-2500 there aren't any DIP switches to set or reset as on most printers, because Se&Type controls these settings.

The four buttons on the panel have multiple names to control different functions. Generally however, they control four areas of printer operation:

- On line/Off line
- Paper feeding
- Print quality/font selection
- SelecType.

### On line/off line

The **ON LINE** button switches the printer between the on line and off *line* states. In the on line state the display reads [ON LINE], which means:

- The printer can receive and print data, and the green **ON LINE**, **POWER**, and **READY** lights are on.
- You can enter the SelecType mode, using the **two ENTER SelecType** buttons.
- You can use the **DRAFT** and **LQ** buttons to select between the two types of print quality: draft and Letter Quality (if you select Letter Quality you can also select among the LQ-2500's five fonts-see Print quality/font selection.)

In the off line state, the display panel reads [OFF LINE], which means:

- The printer cannot receive any data, and the green **ON LINE** and **READY** lights are off.
- You can use the **LINE FEED** button to advance the paper. Pressing the button once advances the paper one line: holding the button down advances the paper continuously. When the power is on, always use this button to advance the paper.



- 
- You can use the FORM FEED button to eject a single sheet of paper or advance continuous-feed paper to the next top of form.

### **Paper feeding**

The LINE FEED and FORM FEED buttons on the panel control paper feeding. The printer must be off line, as indicated in the On line/off line section. When the power is on, you must use these buttons to feed the paper. Using the paper feed knob with the power on can damage the printer mechanism.

### **Print quality/font selection**

When the printer is on line, the DRAFT and LQ buttons can be used to select between the two types of print quality: draft and Letter Quality. With SelecType you can set the LQ-2500 to print in either draft or Letter Quality when you turn the printer on (see Chapter 2).

Whether you choose draft or Letter Quality however, you can still select the other quality setting with the panel buttons; you don't have to go back into SelecType.

If the printer is set for Letter Quality pressing the DRAFT button displays [DRAFT] and selects draft printing.

If the printer is set for draft or Letter Quality pressing the LO button displays the name of the current Letter Quality font, such as [ROMAN], and selects Letter Quality printing in the displayed font. You can also select among the other Letter Quality fonts by pressing the LO button *while the current font* is displayed. See Chapter 5, Selecting fonts with the LQ button, for more information.

When switching between draft and Letter Quality and the five LQ fonts, you may need to change the SelecType Pitch setting. See Chapter 5, Print Pitch and Character Width, for more information.

### **SelecType**

To enter SelecType, the printer must be on line. Press the two buttons labeled ENTER SelecType *at the same time*, and the display reads [SelecType MODE].

---

After entering SelectType, the four buttons on the control panel function according to their SelectType assignments: **EXIT**, **MENU**, **SETTING**, and **OPTION**. See Chapter 2 for a full explanation of SelectType.

### The indicator lights

In addition to the **ON LINE** light, the LQ-2500 has three other lights.

- **POWER**--This light indicates that the printer is turned on and receiving power.
- **READY**--This light comes on when the printer is on line and ready to print. It normally flickers during printing.
- **PAPER OUT**- **This** light indicates that the printer is out of paper. The message [**PAPER OUT**] is also displayed.

---

## 6 Installing the Paper Guide

You can install the paper guide in two different positions. Right now you need to install it to support a single sheet. Before you begin, remove the dust cover so that you can see what you are doing.

### The edge tab

First, put the edge tab into the guide. Squeeze it together as shown in Figure 1-8 and insert the tab into the groove. Then move the edge tab so that it is about 1/4-inch to the left of the widest ridged marking on

---

*Figure 1-8.*  
*Installing the edge tab*

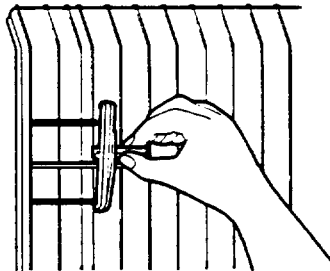

---

the paper guide. This ridged marking corresponds to the extreme left printing position and is called the edge mark.

### **The paper guide**

Second, install the guide itself. Hold the paper guide vertically and lower it so that the slots on either side fit onto the two pins as shown in Figure 1-9 below. Then tilt the paper guide back until it rests at an angle.

---

## **7 Loading Paper**

Even if you normally use continuous-feed paper, it is simpler to test the printer using a single sheet of paper. Be sure to use 14-inch-wide paper so that none of the self test prints on the platen. See Chapter 3 for instructions on loading continuous-feed paper, and information on paper widths and multiple copies.

---

**Figure 1-9.**  
*Installing the paper guide*

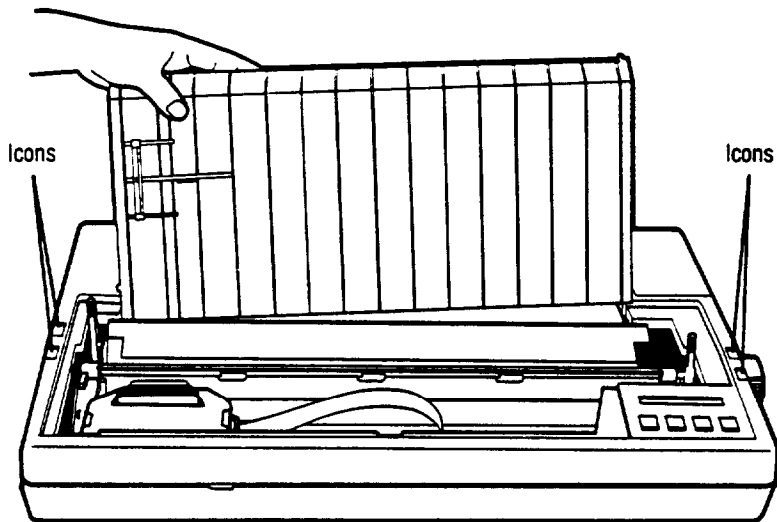

---

## Paper loading icons . . .

Both levers on the LQ-2500 have icons (small pictures) beside them as shown in Figure 1-9. These icons (shown below) remind you whether to push the **lever back** or pull it forward when you load paper.



*Paper release lever back*-When loading single sheets of paper, or using the automatic sheet loading feature, this lever should be back.



*Paper release lever forward*-When using continuous-feed paper, this lever should always be forward.



*Paper bail lever back*-When preparing to use the automatic sheet loading feature, and when actually printing, this lever should be back.



*Paper bail lever forward*-when loading paper with the automatic sheet loading feature, pulling this lever forward loads the sheet.

Now load a sheet of paper:

1. Remove the dust cover. Do not put paper in the printer before you turn it on. The automatic single-sheet loading won't work if paper is loaded before turning the printer on.
2. Now turn the printer ON. The displays reads **[PAPER OUT]**, the printer beeps, and the **PAPER OUT** light comes on.
3. Push the paper release and paper bail levers back. Note that the paper bail lever must be in the printing (back) position now. You will move it to the single-sheet loading (forward) position in step 5.

4. Place the paper on the paper guide with its left edge next to the edge tab as shown in Figure 1-10. Push the paper firmly into the printer, then let go of it. The display changes from [**PAPER OUT**] to [**OFF LINE**].
5. Pull the paper bail lever forward to the single-sheet loading position (indicated by the icon). This feeds the paper into the printer until it is past the paper bail.
6. When the paper stops, push the paper bail lever back to the printing position. This feeds the paper backward until only its top edge is under the paper bail.
7. With the paper loaded, press the **ON LINE** button to place the printer on line. The display reads [**ON LINE**], the green **ON LINE** and **READY** lights come on, and the print head moves to the left **side** of the printer; this is the *home* position. The LQ-2500 is ready to print.

If the platen (the black roller) turns but the paper does not load, remove the paper from the printer and try again, starting at step 3. This time press the paper a little more firmly into place.

If nothing happens at all, see that the printer is turned ON and that the display reads [**OFF LINE**]. Then remove the paper and try again.

*Figure 1-10.*  
*Aligning the paper*

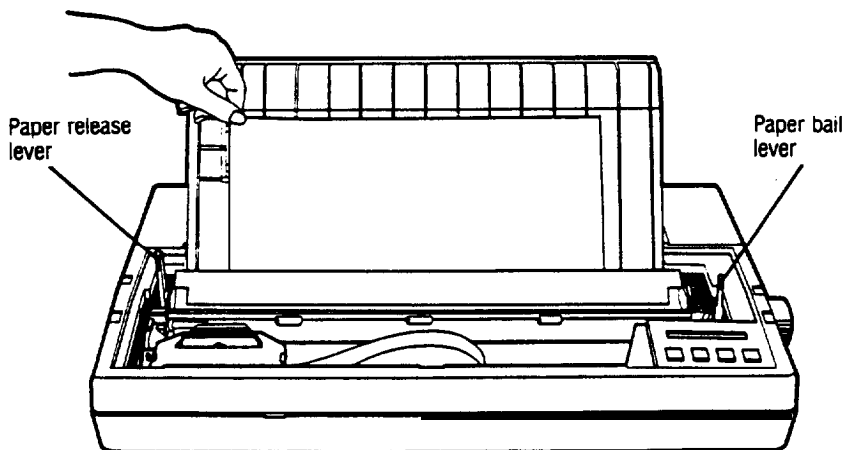

---

## 8 Running the Self Test

The LQ-2500 has a built-in self test that prints out the characters in its memory so that you can be sure the printer is working properly

---

### WARNING

You must load 14-inch-wide paper lengthwise when running the self test. The character sets print in 14-inch lines; if the paper is too narrow, characters print on the platen.

---

Before running the self test, make sure paper is loaded in the printer and that the power is OFF

To run the self test in Letter Quality hold down the LQ button while you turn the printer on. The display reads [SELF TEST]. When printing starts, release the button.

To run the self test in draft mode, hold down the DRAFT button while turning the printer on. The display reads [SELF TEST]. When printing starts, release the button.

As shown on the following page, the self test prints out the current SelecType settings, the default settings, and the version number. (See Chapter 2 for a full explanation of SelecType.)

If you're testing in draft mode, the draft character set begins printing. There is only one style of draft.

If you're testing in Letter Quality mode, the self test prints the character sets of all *five* Letter Quality fonts. It begins by printing the Roman character set, followed by Sans Serif, Courier, Prestige, and Script.

The self test prints out according to the current settings, which are contained in the default macro. If you change the default macro, the self test prints out according to the new macro settings.

For example, the first time you run the self test, the settings should print out in 10 pitch, Letter Quality Roman font, and all the other settings shown under current settings. If you change the default macro to 12 pitch, Letter Quality, Prestige font, with margins of 20 and 60, the self test prints out accordingly

---

The self test printout

|               | Current setting |
|---------------|-----------------|
| >QUALITY      | Draft           |
| >FONT         | Draft           |
| >PITCH        | 10CPI           |
| >CONDENSED    | Off             |
| >FORM LENGTH  | 11.0"           |
| >1" SKIP      | Off             |
| >LEFT MARGIN  | 0               |
| >RIGHT MARGIN | 136             |
| >CG TABLE     | Italic          |
| >COUNTRY      | USA             |
| >PRINT DIR.   | Bi-D            |
| >HALF SPEED   | Off             |
| >SHEET FEEDER | Off             |
| >DEFAULT BIN  | *1              |

|                 | Default setting |
|-----------------|-----------------|
| >INTERFACE      | Parallel        |
| >BAUD RATE      | *9600BPS        |
| >PARITY         | * None          |
| >AUTO LINE FEED | Off             |
| >SLCT-IN        | Valid           |
| >DEFAULT MACRO  | #1              |

### Roman 10

!"#\$%&'()\*+,-./0123456789:;<=>?@ABCDEFGHIJ  
!"#\$%&'()\*+,-./0123456789:;<=>?@ABCDEFGHIJK  
!"#\$%&'()\*+,-./0123456789:;<=>?@ABCDEFGHIJKL  
!"#\$%&'()\*+,-./0123456789:;<=>?@ABCDEFGHIJKLM  
!"#\$%&'()\*+,-./0123456789:;<=>?@ABCDEFGHIJKLMN  
!"#\$%&'()\*+,-./0123456789:;<=>?@ABCDEFGHIJKLMNO  
!"#\$%&'()\*+,-./0123456789:;<=>?@ABCDEFGHIJKLMNOP  
**Sans Serif 10**  
'()\*+,-./0123456789:;<=>?@ABCDEFGHIJKLMNOPQ  
'()\*+,-./0123456789:;<=>?@ABCDEFGHIJKLMNOPQR  
'()\*+,-./0123456789:;<=>?@ABCDEFGHIJKLMNOPQRS  
'()\*+,-./0123456789:;<=>?@ABCDEFGHIJKLMNOPQRST  
'()\*+,-./0123456789:;<=>?@ABCDEFGHIJKLMNOPQRSTU  
'()\*+,-./0123456789:;<=>?@ABCDEFGHIJKLMNOPQRSTUV  
'()\*+,-./0123456789:;<=>?@ABCDEFGHIJKLMNOPQRSTUVW

---

The self test continues until you turn the printer off, or until the printer runs out of paper and displays [PAPER OUT].

---

## 9 Connecting the Printer to Your Computer

Your LQ-2500 has two separate interface connections. Therefore, you must be sure to use the one that your computer requires.

The two interfaces are a Centronic® compatible parallel interface and an RS-232C compatible serial interface. If you have a suitable cable, you can connect most computers immediately

The SelecType Interface setting is set to Parallel at the factory. If you're using the serial interface, be sure to change this setting under \*Change Defaults, as explained in the following chapter on SelecType.

The few computers that require other interfaces can usually use one of the optional interface boards described in Appendix F. Check your computer's manual if don't know which interface to use.

### The parallel interface

Before connecting a parallel interface cable, see that both the printer and computer are turned off. Then plug the connector into the printer as shown in Figure 1-11. Nest squeeze the clips gently and click them into place.

---

*figure 1-11.*  
**Connecting the parallel cable**

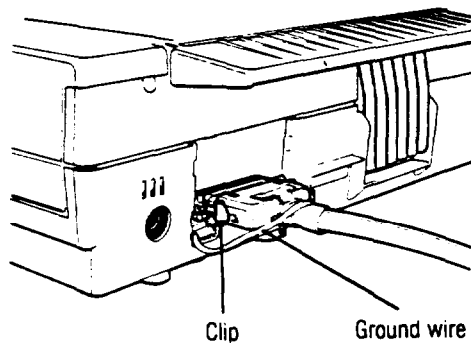



---

Some parallel cables have a ground wire. Connect this wire to the ground screw on the printer to protect data from interference. Then plug the other end of the cable into the computer and connect the ground wire on the computer end of the cable if it has one.

Parallel interfaces require no further adjustment.

The serial interface

For the serial interface, you should use an Epson serial interface cable. Use #8239 for the Apple® IIc, #8297 for the IBM® PC and compatibles, and #8293 for most other computers with a DB-25 socket, including the Apple IIe with serial interface. (Although you can use the serial interface with an IBM or compatible computer, it is usually best to connect the LQ-2500 to the parallel port of an IBM or compatible computer.)

The serial interface also requires that you change the SelectType Interface setting under \*Change Defaults, as well as two other settings, Baud Rate and Parity. See the next chapter on SelectType for more information.

---

## 10 A Final Checklist

Now that you've completed the basic setup and self test, your LQ-2500 is ready to print. If you've had any difficulties so far, run down this brief checklist to be sure the printer is properly set up.

- Were you able to run the self test successfully? If not, try reloading the paper, and check that all packing materials have been removed from the printer
- Is the power source (power strip, etc.) turned on?
- Is the ribbon properly installed? Check that the tab on the ribbon cartridge is resting on the support ridge on the carriage. Make sure the pins on the cartridge are in the holes on the carriage.
- Before loading continuous-feed paper, read Chapter 3.

- 
- With a single sheet of paper loaded, are the POWER, ON LINE, and READY lights on, and does the display read [ON LINE]? If not, press the **ON** LINE button to place the printer on line. If the display reads [PAPER OUT] and the PAPER OUT light is on, check that you've loaded the paper correctly
  - Is your printer properly connected to your computer? Are you using the correct interface (serial or parallel)? If you're in doubt, check your computers documentation.

Before you actually print a document with an application program, read the following chapter on SelecType.

SelecType separates the LQ-2500 from all printers that have gone before it. The SelecType panel lets you control almost all printer functions, while displaying exactly what's going on.

After reading about SelecType, continue to Chapter 4 where Table 4-1 shows which printers you should select when setting up your application programs.

Additional chapters cover the LQ-2500's many fonts, timesteps, and enhancements as well as the graphics and userdefined character features. The appendixes in the back of this manual include the LQ-2500 Command Summary (Appendix A), plus character tables and additional technical information.

# SelecType

SelecType on the LQ-2500 brings a new dimension to printing. With SelecType you can now control almost every aspect of printer operation.

SelecType lets you:

- Use four preset macros-stored groups of settings that you can recall with the touch of a button
- Replace the preset macros with your own custom-designed macros
- Set up to 20 printer settings from the SelecType panel
- Choose among the LQ-2500's five *built-in* fonts
- Print out the printers settings with a touch of a button
- Monitor the LQ's settings with the LCD panel
- Change the LQ's default settings without DIP switches, and more.

The four preset macros cover general applications: Draft/word processing, Letter Quality/word processing, Spreadsheets, and Graphics. However, you can create your own macros with any of the LQ's settings.

There are no switches to reset or commands to send, you simply **load** the macro you want, then print. In fact, the LQ-2500 has no DIP switches. All of these functions can now **be** controlled through SelecType.

## Using SelecType

The easiest way to learn SelecType is to read this chapter. Then start pressing buttons. There is also a SelecType Quick Reference card in the back of this manual which gives an overall diagram of SelecType.

---

## The SelecType Panel

The SelecType panel is the part of the main control panel that deals with SelecType. The SelecType controls are shown in **blue in** Figure 2-1 on the next page. They include the **two ENTER SelecType** buttons, and the four buttons labeled **EXIT**, **MENU**, **SETTING**, and **OPTION**. The LCD shows SelecType messages and settings.

---

When you press the two ENTER **SelecType** buttons, the four control panel buttons switch to their SelecType labels. The control panel buttons cannot be used for their other labeled functions until you exit SelecType.

---

## Entering **SelecType**

1. Make sure that the power is on, and that the printer is on line. (The green ON LINE, POWER, and READY lights are on, and the display reads [ON LINE].)
2. To enter SelecType, press the two ENTER **SelecType** buttons *at the same time*. The display reads [SelecType MODE].

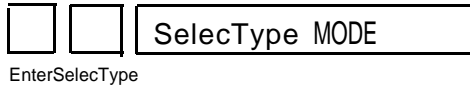

---

Figure 2-1.  
The SelecType panel

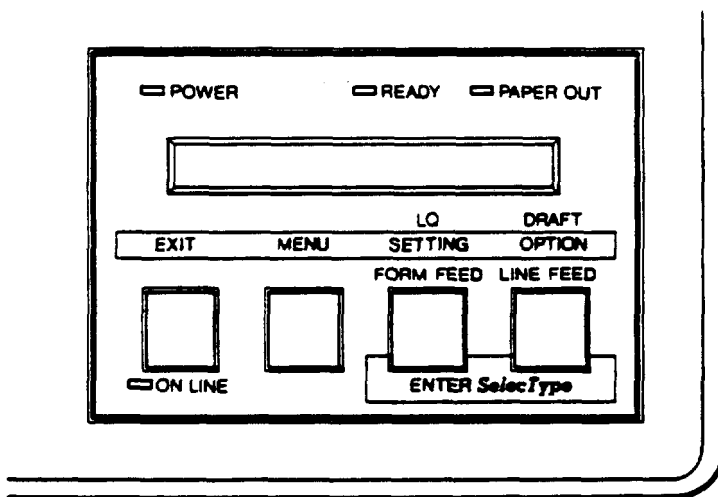

---

## The SelecType Main Menu

The SelecType main menu lists the four modes that let you control printer functions and operation. Whenever you exit from any of the modes, you *always return to the main menu*. An \* next to the name of the **mode** indicates that you're in the main menu.

1. After activating SelecType, press **MENU** to view the four modes on the main menu. The four modes are:
  - \***LOAD MACRO**-This mode lets you load one of the four macros to accommodate your own printing needs.
  - \***CHANGE MACRO**-This mode lets you change the current printer settings, with the option of creating and saving your own macros.
  - \***CHANGE DEFAULTS**-This mode lets you define the settings that will be in effect each time you turn on the printer.
  - \***PRINT OUT SETTINGS**--This mode prints out the current printer settings, the settings for the four macros, and the default settings.
2. To enter any of the four modes, press **MENU** until the display shows the mode you want. Then proceed according to the instructions for that particular mode.
3. Pressing **EXIT** at any time while you're in the main menu takes you out of the SelecType mode and returns the printer to the on line state. The display reads [ON **LINE**].

---

### Note

The \*Print Out Settings mode is covered at the end of this chapter. However, you may find it useful to learn this mode *first*, because it may help you in learning the other three modes.

---

---

## \* LOAD MACRO

The \*Load Macro mode lets you load one of the preset macros, or a macro you've created. You can use the \*Change Macro mode to create and save your own macro.

When you turn the printer on, one of the four macros is loaded automatically as the *default* macro. As described under \*Change Defaults mode, the preset default macro is macro 1.

### The preset macros

While you're learning SelecType, you may want to use the four preset macros. These macros are set for use with general application programs.

The facing page shows samples printed out with these four macros. You can use the \*Print Out Settings mode to see the specific settings contained in these macros.

*Macro 1*--Draft printing/word processing. This macro is set for high-speed, draft quality printing. It can be used for word processing to print rough drafts, or for any application where you need a job printed in a hurry. See Chapter 4 for more information on word processors.

*Macro 2*--Letter Quality printing/word processing. This macro is set for Letter Quality printing. It can be used for word processing to print a final document, or for any application where you want a polished result. Although the Roman font is installed for this macro, you can select any of the other Letter Quality fonts with the LQ button (see Chapters 1 and 5) or by selecting another font in the \*Change Macro mode.

*Macro 3*--This macro is set specifically for printing spreadsheets. If your spreadsheet and paper is wide enough, it prints across the full width of the carriage (14 inches). This macro also calls for condensed printing which allows up to 233 columns across a page. See Chapter 4 for more information on spreadsheets.

*Macro 4*--This macro is set specifically for printing character graphics. It takes advantage of the Epson Graphic character table to print lines, corners, and shaded areas as shown on the following page. See Chapters 4 and 6 for more information on graphics programs.

---

## Macro #1

Preset macro #1 is set for draft printing/word processing to produce high-speed, draft quality printing. It can be used for word processing to print rough drafts, or for any job you need printed in a hurry. You can also use enhancements and print styles, including *italic*, *double-width*, and emphasized.

## Macro #2

Preset macro #2 is set for Letter Quality printing/word processing in the Roman font. It can be used for word processing or any application where you want a polished result. You can also use enhancements and print styles, including **italic**, **double-width**, and **emphasized**.

## Macro #3

### SALES REPORT

|             | Jan | Feb | Mar | Apr | May | Jun |
|-------------|-----|-----|-----|-----|-----|-----|
| J. Smith    | 784 | 548 | 475 | 648 | 874 | 654 |
| T. Jones    | 774 | 758 | 655 | 754 | 789 | 885 |
| L. Williams | 756 | 752 | 852 | 841 | 740 | 887 |

## Macro #4

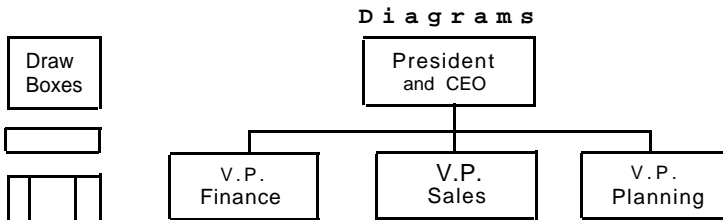

When loading another macro, the new macro's settings immediately become the printer's current settings. (See \*Change Macro for a full explanation of current settings.) The first macro isn't lost, because it remains stored in the LQ's memory—that's the advantage of a macro.

After loading a macro, you can still change the current settings with the \*Change Macro mode. You might load a macro that calls for a right margin of 79. If you decide you want to change the right margin to 135 for only one document, you could use \*Change Macro to reset the current setting to 135. However, the next time you recall the macro, it would still have the original setting of 79.

### Loading a macro

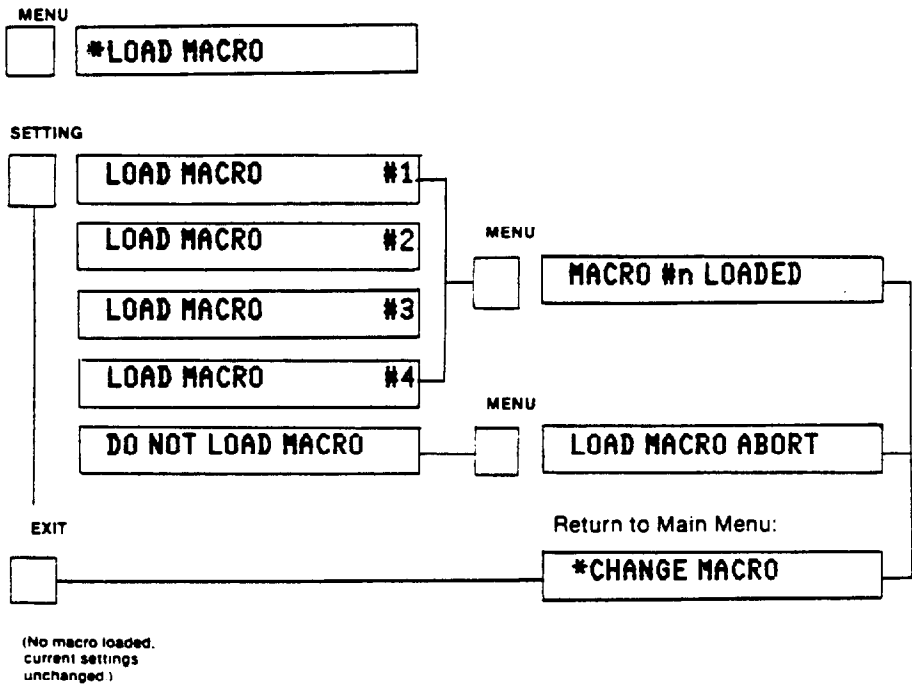

1. From the SelecType main menu, press MENU until the display shows [\*LOAD MACRO].
2. Press SETTING to display the five choices, as shown above. You can choose to load one of the four macros, or not load any macro.



- 
3. To load a macro, press **SETTING** to display the macro number you want to load.
  4. Press **MENU** to load that macro. The display shows the macro number that is loaded [MACRO #n LOADED], then returns to the main menu.

### **Aborting or exiting**

1. If you decide you don't want to load a macro, you can choose the [DO NOT LOAD MACRO] option. Press **MENU** and the display shows [LOAD MACRO ABORT], then returns to the main menu.
2. Pressing **EXIT** at any time while you're in the \*Load Macro mode takes you back to the main menu without loading a macro. Pressing **EXIT** does not display a message, it simply takes you back to the main menu.

---

## \*CHANGE MACRO

The 14 settings and their options shown in Table 2-1 control printing and printer operation. These settings are the heart of the SelecType system. (There are additional settings that can be changed in the \*Change Defaults mode.) If you are unfamiliar with any of the terms in the table, consult the Glossary in the **back** of this manual.

Table 2-1. Printer settings and options

| Select with SETTING | Change with OPTION  |
|---------------------|---|
| PRINT QUALITY       | Draft. LQ   |
| FONT                | Roman, Sans Serif. Courier. Prestige, Script  |
| PITCH               | 10CPI, 12CPI, 15CPI. Proportional   |
| CONDENSED           | On. Off   |
| FORM LENGTH         | xx.x" (4"--22" in 1/2" steps)   |
| 1" SKIP             | On. Off   |
| RIGHT MARGIN        | xxx (Left margin + 1-136)   |
| LEFT MARGIN         | <b>xx (0-80)</b>  |
| CG TABLE            | Italic. Graphic. Download   |
| COUNTRY             | USA. France. Gem-any UK. Denmark 1, Sweden, Italy, Spain 1, Japan, Norway, Denmark 2, Spain 2, L. America |
| PRINT DIR           | Bi-D. Uni-D   |
| HALF SPEED          | On. Off   |
| SHEET FEEDER        | Off. Single. Double   |
| -DEFAULT BIN        | <b>1, 2</b>   |

'Default bin is displayed only when double-bin sheet feeder is selected,

The LQ-2500 uses a list of these settings, called the *current* printer settings, whenever it prints. This means there are actually six lists of settings stored in the printers memory-the current printer settings, the settings for each of the four macros, and the default settings (see the following section on \*Change Defaults for more information).

---

These current settings can be printed out with the \*Print Out Settings mode, described later in this chapter. A sample printout appears below.

|               | Current setting |
|---------------|-----------------|
| >QUALITY      | Draft           |
| >FONT         | Draft           |
| >PITCH        | 10CPI           |
| >CONDENSED    | Off             |
| >FORM LENGTH  | 11.0"           |
| >1" SKIP      | Off             |
| >LEFT MARGIN  | 0               |
| >RIGHT MARGIN | <b>136</b>      |
| >CG TABLE     | Italic          |
| >COUNTRY      | USA             |
| >PRINT DIR.   | Bi-D            |
| >HALF SPEED   | Off             |
| >SHEET FEEDER | Off             |
| >DEFAULT BIN  | *1              |

Whenever you **load** a macro, the new macro settings become the current settings (although the macro remains **stored** in memory). You then have the option of:

- Changing only the current printer settings, or
- Changing the current settings and saving them **as a macro**.

Changing only the current settings is useful when you want different settings for only one print **job**, but you don't want to permanently change **a macro**. For example, you may have one macro set for business correspondence in Letter Quality with the Courier font. If you wanted to write a letter to a friend, you could use that same macro, change to the more informal Sans Serif font, but not save the setting. This **would preserve** the original macro.

On the other hand, you might change the current settings, then find you like the new settings more than the original macro settings. You could save the new settings as a macro, replacing the original settings.

If you change only the current settings, the new settings remain in effect until you change them again, or until you turn the printer off. When you turn the printer off, the original macro remains stored in memory, but any changes are lost. If you want to save the new settings, you must save them as a macro.

---

With the \*Change Macro mode you *always change* the current settings. As soon as you choose and set a different option, that new choice becomes a current printer setting.

## Changing the current settings

There are two ways to change the current settings.

- You can use the DRAFT and LQ buttons on the control panel to change print quality or font, as described in Step 5, Chapter 1.
- You can use the \*Change Macro mode to change the current settings without saving the settings to a macro.

To change the current settings, follow these steps.

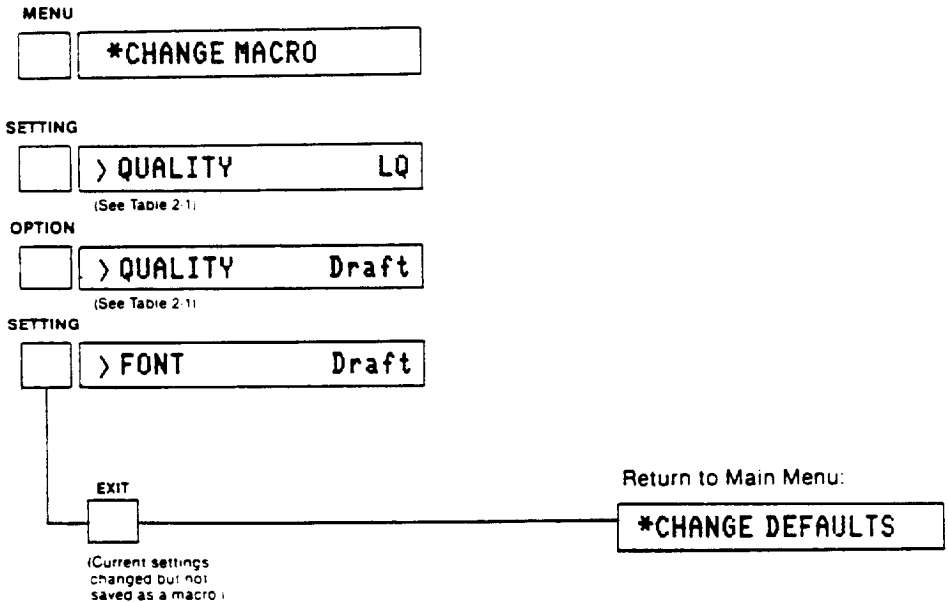

1. From the SelecType main menu, press **MENU** until the display shows [**\*CHANGE MACRO**].
2. Press **SETTING** to see the printer settings listed in Table 2-1.
3. Select a setting you want to change, then press **OPTION** to display the options for that setting.

- 4 When you see the option you want, leave it displayed.
5. Now press **SETTING** again. When you press **SETTING** after **OPTION**, the displayed option becomes the current printer setting. The display then advances to the next setting according to Table 2-1.

### Caution

When you change an option, It *immediately* changes the current setting. You can still choose whether or not to save the new setting as a macro, but you can't undo the change without changing it again.

6. After changing the settings (you can change as few or as many as you want), press **EXIT**. SelecType returns to the main menu with the current settings changed but not saved as a macro.
7. Use the \*Print Out Settings mode to confirm the new settings.

Changing the current settings and saving them as a macro

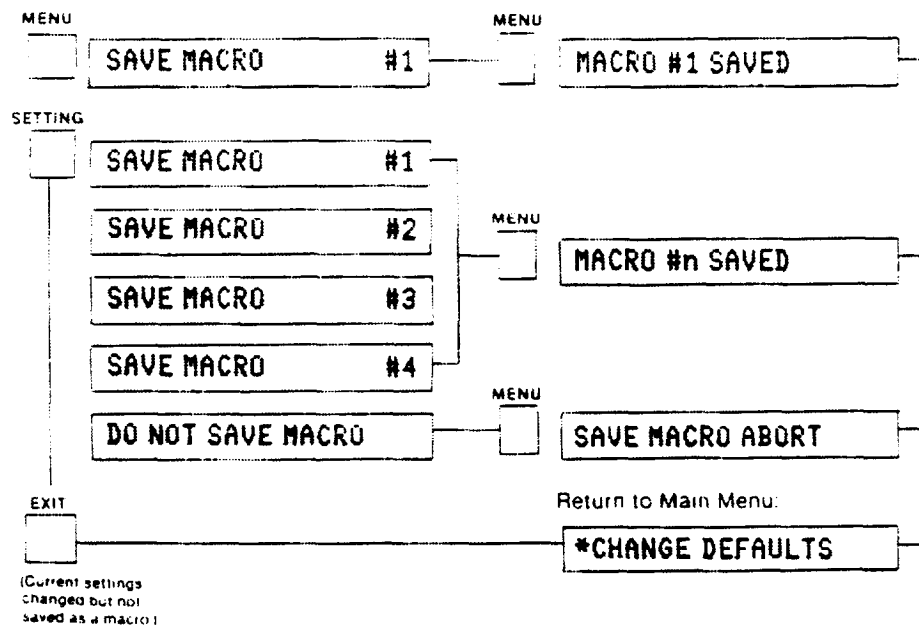

- 
1. Select the settings and options you want to change as described in the previous steps 1-5. Whether you're just changing the current settings, or saving them as a macro, selecting the settings and options is the same.
  2. After changing the settings (you can change as few or as many as you want), press MENU. The display shows [SAVE MACRO #1]. If you press MENU again, the display shows [MACRO #1 SAVED], then returns to the main menu.
  3. To select another macro number for the new macro, press SETTING. As shown on the previous page, you can select macro 1 through 4, or choose not to save the macro.

---

**Note**

The LQ-2500 is delivered with four preset macros. A new macro will always replace an old one, whether it's a preset macro or one that you create. When replacing a macro, you may be replacing the *default* macro. See \*Change Defaults mode for more information.

---

4. Leave the new macro number on the display and press MENU. The display reads [MACRO #n SAVED], then returns to the main menu.
5. Use the \*Print Out Settings mode to confirm the new macro and current settings.

**Aborting or exiting**

1. If you decide you don't want to save the settings as a macro, choose the [DO NOT SAVE MACRO] option. Press MENU and the display shows [SAVE MACRO ABORT], then returns to the main menu.

---

**Note**

Even if you choose not to save changes as a macro, you have still changed the current settings. Aborting or exiting from the Save Macro section does not abort any current settings you may have changed.

---

2. Pressing EXIT at any time while you're in the Save Macro section takes you back to the main menu without loading a macro. Pressing EXIT does not display a message, it simply takes you back to the main menu.

---

## \*CHANGE DEFAULTS

The *defaults* are the settings in effect when you turn the printer on. Table 2-2 shows the default settings and options for the LQ-2500. If there are any terms you don't understand, consult the Glossary at the back of this manual.

Table 2-2. Default Settings and Options

| Select with Setting | Change with Option  |
|---------------------|---|
| INTERFACE           | Parallel, Serial  |
| *BAUD RATE          | 300BPS. 600BPS. 1200BPS. 2400BPS. 4800BPS.<br>9600BPS. 19200BPS |
| • PARITY            | None. Even. Odd. Ignore   |
| AUTO LINE FEED      | On. Off   |
| SLCT-IN             | Valid. Invalid  |
| DEFAULT MACRO       | #1, #2, #3, #4  |

\*These settings, and their options, are displayed only when the Serial Interface setting is selected.

### The preset defaults

When you receive your LQ-2500, the defaults are already set for a parallel interface. The \*Print Out Settings mode lists the default settings, as shown below.

```

                                Default setting
>INTERFACE                      Parallel
>BAUD RATE                      *9600BPS
>PARITY                          *   None
>AUTO LINE FEED                 Off
>SLCT-IN                        Valid
>DEFAULT MACRO                  #1
```

---

### Note

If you change the default settings, the printer does not recognize the new settings until you turn the power OFF then turn it back ON again.

---

---

## Default macro

The preset defaults include a *default* macro. Each time you turn the LQ-2500 on, it needs setup instructions. The LQ-2500 uses the settings contained in the default macro to prepare for printing.

When you receive your LQ, the default macro is set for macro 1. This means that when you turn the printer on, it prints according to the settings listed in macro 1.

The Default Macro setting gives you the option of selecting any of the four macros as the default macro. For example, if you print spreadsheets most of the time, you could select the preset macro 3 as the default macro. Or you can create and save you own macro as the default macro.

## Parallel interface systems

If your computer has a parallel interface, the preset defaults should work correctly. Check your computer manual to confirm that it uses a parallel interface.

Although the list of defaults includes Baud Rate and Parity settings, these apply only to *serial* interfaces. As indicated on Table 2-2, the display does not show these settings if the parallel interface option is selected.

## Serial interface systems

If your computer has a serial interface, you'll need to change the defaults. When you select the serial interface option, you will then need to set both the baud rate and parity.

*Baud rate* is the rate at which the printer receives data from the computer. The LQ-2500 has seven baud rate settings from 300bps to 19200bps (bps means *bits* per second). You should check your computer manual (or application program) for the correct baud rate setting. Your computer and printer should always be set to the same baud rate.

*Parity* is a method for a computer and printer to check the reliability of data transmission. Again, check your computer manual and make sure your computer and printer have the same parity setting.



## Auto Line feed and SLCT-IN

Most application programs send automatic line feeds at the end of every line, so this option should remain Off. However, if all of the lines are printing on top of each other, change this setting from Off to On.

For most application programs, and most uses, the SLCT-IN setting should remain Valid. This means that the printer cannot be deselected or reselected by the DC1 or DC3 control codes (see Appendix A for further explanation). If it's set to invalid, the printer can be deselected or reselected by DC1 or DC3.

## Changing the defaults

To change the default settings, follow these steps.

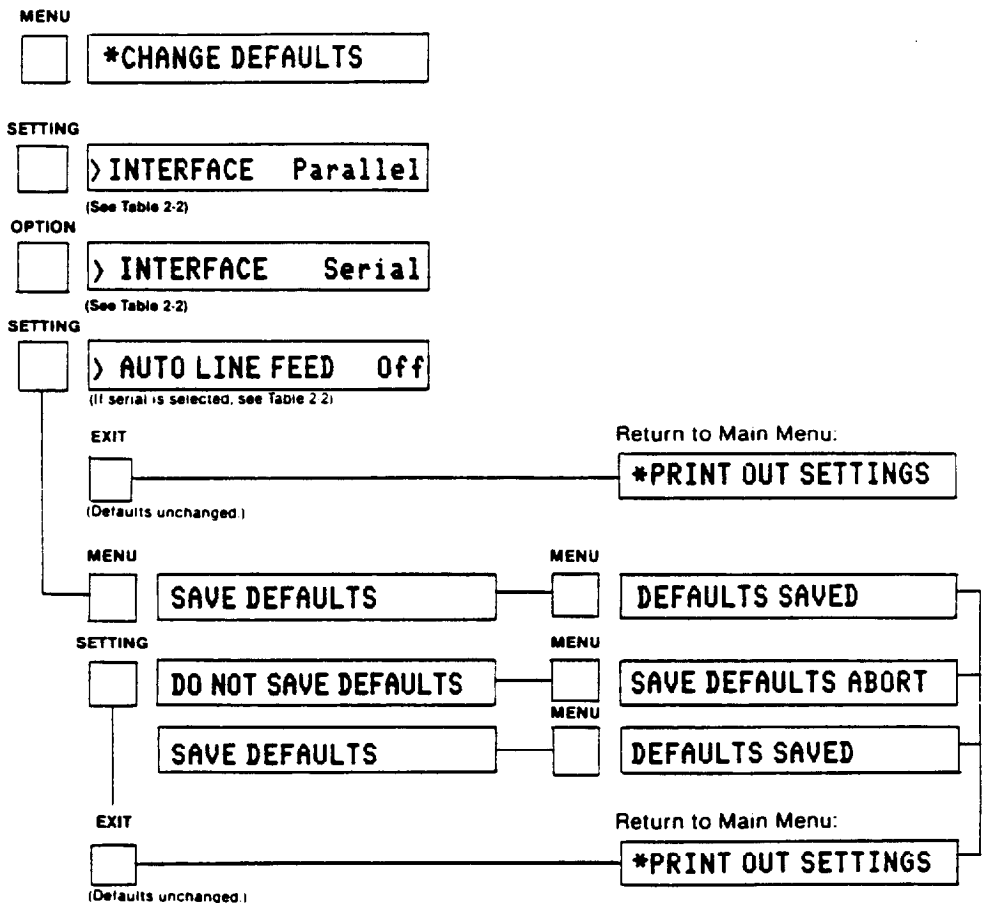

- 
1. From the SelecType main menu, press MENU until the display shows [\*CHANGE DEFAULTS].
  2. Press SETTING to see the default settings listed in Table 2-2.
  3. Select a setting you want to change, then press OPTION to display the options for that setting.
  4. When you see the option you want, leave it displayed.
  5. Now press SETTING again. When you press SETTING after OPTION, the option is selected, but its not stored as a default setting until you *save* the defaults.

---

**Note**

The \*Change Defaults mode differs from the \*Change Macro mode at this point. If you change a default setting, it's not stored as a default setting until you *save* the defaults. In the \*Change Macro mode, changing a setting *immediate/y* changes the current setting.

---

6. After changing the settings (you can change as few or as many as you want), press MENU. The display shows [SAVE DEFAULTS]. If you press MENU again, the display shows [DEFAULTS SAVED], then returns to the main menu.
7. Pressing SETTING gives you the option of either saving the defaults or not saving the defaults. as shown on the previous page. To save the defaults, leave [SAVE DEFAULTS] displayed.
8. Press MENU and the display reads [DEFAULTS SAVED], then returns to the main menu.
9. Turn the power OFF and then back ON again so the printer recognizes the new defaults.
10. Use the \*Print Out Settings mode to confirm the new default settings.

---

## Aborting or exiting

1. If you decide you don't want to change the default settings, choose the [DO NOT SAVE DEFAULTS option. Press MENU and the display shows SAVE DEFFIULTS ABOUT], then returns to the main menu, leaving the defaults unchanged.
2. Pressing EXIT at any time while you're in the \*Change Defaults mode takes you back to the main menu, leaving the defaults unchanged. Pressing EXIT does not display a message, it simply takes you back to the main menu.
3. Turn the power OFF and then back ON again so the printer recognizes the default settings.
4. Use the \*Print Out Settings mode to confirm that the default settings are unchanged.

---

## \*PRINT OUT SETTINGS

The \*Print Out Settings mode gives you an immediate printout of the six SelecType listings, as shown below. (Although the print quality calls for draft, this printout is in Letter Quality)

```
Current setting
>QUALITY           Draft
>FONT              Draft
>PITCH             10CP1
>CONDENSED        Off
>FORH LENGTH      11.0"
>1" SKIP          Off
>LEFT MARGIN      0
>RIGHT MARGIN     136
>CG TABLE        Italic
>COUNTRY          USA
>PRINT DIR.       BI-D
>HALF SPEED       Off
>SHEET FEEDER    Off
>DEFAULT BIN      *1

Macro #1          Macro X2          Macro #3          Macro X4
>QLJALITY         Draft           LQ              Draft           LQ
>FONT             Draft           Roman           Draft           Sans Serif
>PITCH            10CP1          10CP1          10CP1          10CP1
>CONDENSED        Off            Off            Off            Off
aFORM LENGTH      11.0"         11.0"         11.0          11.0"
>1" SKIP          Off            Off            Off            Off
>LEFT MARGIN      0              0              0              0
>RIGHT MARGIN     136           80             136            136
>CG TABLE        Italic         ltalic          Italic          Graphics
,COUNTRY          USA            USA            USA            USA
>PRINT DIR.       Bi-D           Bi-D           Bi-D           Bi-D
>HALF SPEED       Off            Off            Off            Off
>SHEET FEEDER    Off            Off            Off            Off
>DEFAULT BIN      *1            *1            *1            *1

Default setting
>INTERFACE         Parallel
>BAUD RATE        * 9600BPS
,PARITY            * None
>AUTO LINE FEED   Off
>SLCT-IN          Valid
>DEFAULT MACRO    t1
```

This mode is an invaluable tool for evaluating SelecType. You can check the macro settings and defaults to decide if theres anything you want to change. Or you can make a printout whenever you change settings, to make sure the changes are what you want.

The printout is eight inches wide, so it fits easily on standard letter-size paper.

---

## Printing out the settings

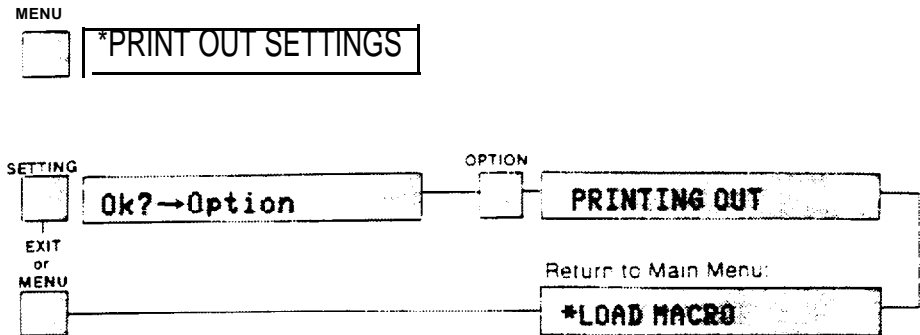

1. From the **Select Type** main menu, press **MENU** until the display shows [**\*PRINT OUT SETTINGS**].
2. Now press **SETTING**. The display shows [**OK?-Option**] for confirmation.
3. If you want to print, press **OPTION** to begin printing. The display reads **I PRINTING OUT I**, and automatically prints all the **SelectType** settings. When printing is complete, the display returns to the main menu.

## Exiting

1. At any time during the printout, you can press **EXIT** or **MENU** to stop the printing and return to the main menu.

## Choosing and Loading Paper

The LQ-2500 printer can accommodate many different sizes and types of paper, using either its automatic single-sheet loading feature or its built-in adjustable tractor.

The tractor is easy to use and can handle a wide range of paper widths. The automatic single-sheet loading feature handles individual sheets quickly and easily and for greater efficiency you can add an optional automatic sheet feeder.

---

### Choosing Paper

Without installing any accessories, you can use single-sheet paper from 7 1/4 to 14 inches wide, and continuous-feed paper from 4 to 16 inches wide (including the perforated edge strips).

#### Carbon copies

If you use multi-part forms or carbon copies in the LQ, use no more than four sheets or parts at a time, with a total thickness of no more than 0.22 mm. . Also so change the paper thickness setting as described at the end of this chapter.

---

### Loading Single Sheets

You have already loaded single-sheet paper using the automatic sheet loading feature in Step 7 of the setup chapter. This feature gives you short printing times by combining fast loading with fast printing.

If you print large amounts on single sheets of paper, however, you may find it more convenient to use an automatic sheet feeder. This is an optional device that holds a stack of paper and inserts a new sheet

---

whenever required, making single sheets as easy and convenient to use as continuous-feed paper. The automatic sheet feeder has its own users manual.

### Reloading during printing

When you print a document more than one page long using single sheets of paper, there are two different ways your application program can allow you to load a new sheet at the end of a page.

- If the program sends characters in a continuous stream, the printer stops printing when it reaches the bottom of the paper and sounds the beeper. When this happens, the **ON LINE** light goes off automatically
- If the program handles printing page by page, it probably stops sending characters at the end of a page and prompts you to insert more paper. In this case the **ON LINE** light probably remains on, and the first thing you should do is press the **ON LINE** button once to turn it off.

Once the **ON LINE** light is off, remove the sheet that has just been printed and load a new sheet in the same way as before.

---

## Loading Continuous-feed Paper

The new push-feed tractor built into the LQ-2500 has several major advantages over other types. It combines the ability to handle a wide range of paper widths with an extremely low profile, and it is easy to load.

The push-feed tractor must be loaded in a slightly different way than the pin-feed system on Epson FX printers and the usual pull-through tractors. If you are used to other systems, follow these instructions carefully

Begin by making sure that the printer is turned off. If you have been using the printer with single sheets, remove the paper guide. You will install it in a different way

---

Clear enough space around the printer so that the paper has an unobstructed path in and out of the printer. There are three common methods of arranging a printer and continuous-feed paper:

- Using a printer stand with the paper stacked underneath it.
- Using a desk or table as a stand, with the printer near the rear edge and the paper on the floor or on a shelf.
- Putting the printer on a desk or table and stacking the paper behind the printer.

Now follow these steps to load continuous-feed paper in your LQ-2500.

1. Install the paper rest by fitting its hooks into the notches at the back of the printer, as shown in Figure 3-1. This prevents incoming paper from catching on the cable.
2. Release the sprocket units by pushing the locking levers back, as shown in Figure 3-2.
3. Remove the dust cover and move the print head to about 40 on the ruler on the paper bail.
4. Pull the paper bail and paper release levers forward.

---

*Figure 3-1.*  
*installing the paper rest*

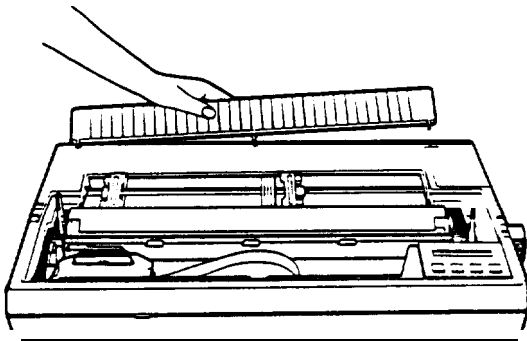

*figure 3-2.*  
*Releasing the sprocket units*

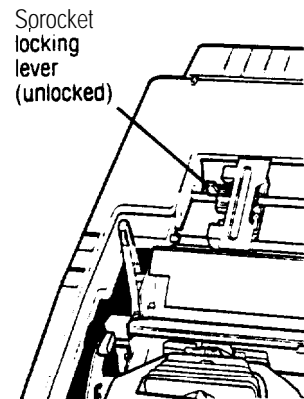



- 
5. Move the left sprocket unit all the way to the left and pull the locking lever forward to hold it in position.
- 

Note

With the sprocket unit in this position, you always have a margin at the left side. If you want to print without a left margin, or if your program creates a margin, move the left sprocket unit about 3/4-inch from the left side, so that the perforated edge of the paper lines up with the number 1 on the ruler on the paper bail. Check the exact position when you finish loading.

---

6. Open the covers on the sprocket units as shown in Figure 3-3, then move the right sprocket unit to its approximate position, using your paper as a guide. Space the paper support between the sprocket units.
7. Make sure that the first sheet of paper has a clean edge and that the perforated edges are still attached.
8. Fit the first four holes in the left side of the paper over the pins of the left sprocket unit, as shown in Figure 3-4; then close the cover.
9. Now move the right sprocket unit so that you can fit the holes in the paper over the pins and close the cover.

---

*Figure 3-3.*  
*Opening the sprocket units*

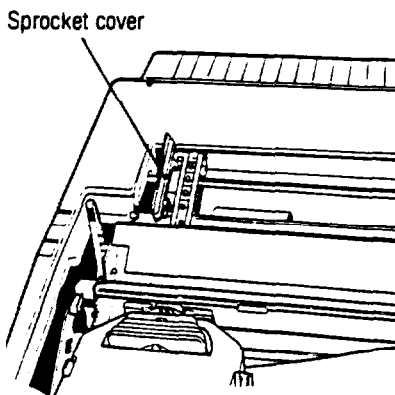

---

*Figure 34.*  
*Positioning the paper*

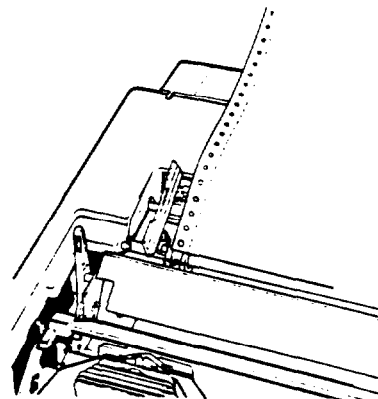

- 
10. If the paper is straight and has no wrinkles, **lock** the right sprocket unit in place.
  11. Turn the paper feed knob slowly to feed the paper under the metal plate in front of the tractor. (The diagram on the metal plate shows how the paper should go through.) Make sure the paper does not wrinkle after it reaches the platen.
  12. Turn the knob until the paper is past the paper bail. Then push back the paper bail lever (the lever on the right side). The paper bail lever must be back at all times when you are printing with continuous-feed paper.

### Installing the paper guide

Install the paper guide to prevent the outgoing paper from being pulled back into the printer- This is the same part that supports the paper when you print on single sheets, but with continuous-feed paper, it is installed horizontally

The paper guide has notches at either side that fit over two pins located at the **sides** of the tractor.

1. Hold the paper guide vertically above the printer, with the curved end down, as shown in Figure 3-5.
2. Lower the notches onto the pins as shown below, then tilt the paper guide **back** until it lies horizontally over the paper.

---

*figure 3-5.*  
*Installing the paper guide*

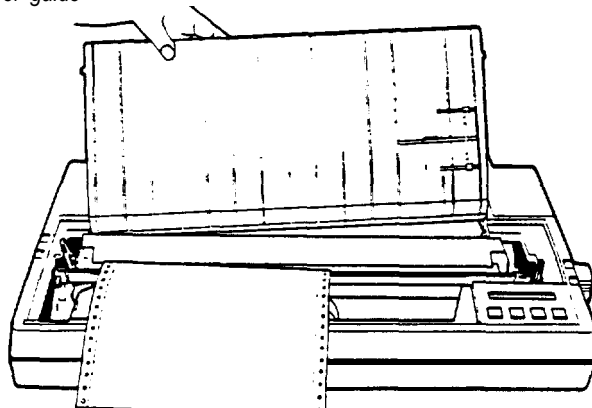

---

## Setting the top of form position

Finally you need to establish a top of form position so that the printer does not print on the perforations. The top of form position is the position of the paper when the power is turned on. This position is also reset whenever a program initializes the printer or sets the page length.

Setting the top of form position is a simple three-step process:

1. See that the printer is turned off.
2. Use the paper feed knob to advance the paper until the first row of perforations is just above the paper bail as shown in Figure 3-6.
3. Turn the printer on.

The printer remembers this position and keeps track of how far the paper has been advanced. This way when you want to move to the top of a new page, it always knows how far to advance the paper.

For some programs, it is more convenient to set the top of form at the top of the print head. Try this if the setting above the paper bail does not work correctly with your program.

---

*figure 3-6.*  
*The top of form setting*

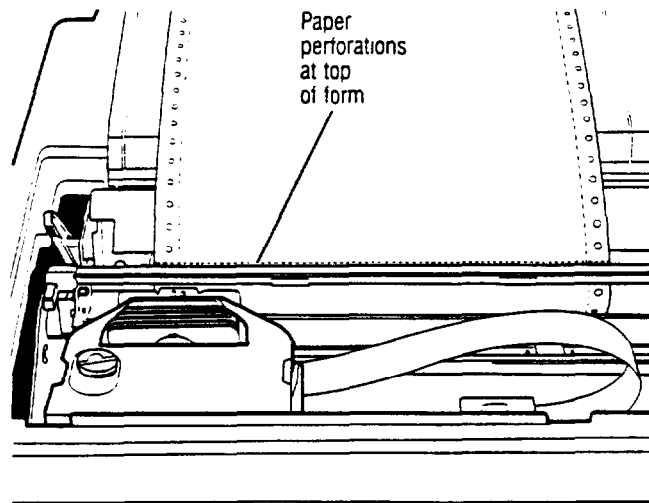

---

Remember that you should never advance the paper using the paper feed knob while the power is turned on. You can damage the mechanism of the printer, and the printer will lose track of the top of form position.

---

## **Loading Labels**

You can use labels on a continuous-feed backing, with a perforated backing sheet for use with the tractor. The minimum width of a tractor-fed label is four inches, including the full width of the backing paper.

The procedure for loading labels with the tractor is the same as for loading continuous-feed paper, except for two points. Labels on a backing sheet are thicker than normal paper. Therefore, you must adjust the paper thickness lever, which is described at the end of this chapter. Also, if you don't want a left margin on the labels, move the left sprocket unit about 3/4-inch from the left side before locking it in position.

---

### **WARNING**

Never turn labels backward with the paper feed knob. Labels can peel off the backing and jam the printer. If a label does become stuck in the printer, see your authorized Epson dealer. Do not attempt to remove the labels yourself.

---

When you are through printing on labels, tear them off at a perforation behind the platen: then feed the remainder through. It is better to waste a few labels than to risk damaging the printer.

It is also possible to buy labels on a matte backing in single sheets. (Labels on a shiny backing sheet will almost always slip a little if fed by friction alone.) Single-sheet labels must be a minimum of 7.15 inches wide.

There are normally no gaps between individual labels on the sheet, so that the labels are less likely to catch on the platen. You can load these with the automatic single-sheet loading feature.

---

## The Paper Thickness Lever

You can adjust the LQ-2500 to accommodate different thicknesses of paper. You need to do this when you print labels or carbon copies. Before moving the paper thickness lever, always turn off the power and open the dust cover.

The paper thickness lever has four positions. You can identify these by looking at the catch positions in the metal plate, as shown in Figure 3-7.

For normal use the lever should be in the second position away from the platen as shown in Figure 3-7. For printing labels, carbon, or carbon-less copies, move the lever to the third or fourth position away from the platen. This slows down the print head to increase the impact, which gives clearer, darker copies.

Always return the lever to the normal position when you resume printing on normal paper

---

*Figure 3-7.*  
*Paper thickness lever*

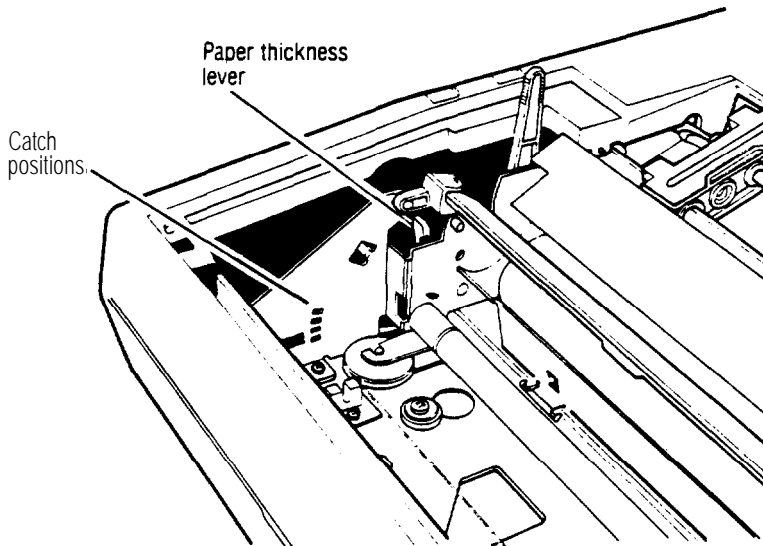

---

| <b>Paper thickness</b> | <b>Lever position</b> |
|------------------------|-----------------------|
| Standard               | Second                |
| Thinner                | Second or first       |
| With one copy          | Third or fourth       |
| With two copies        | Fifth                 |
| With three copies      | Sixth                 |

Always return the lever to the normal position when you resume printing on normal paper.

## Using the LQ-2500 with Application Programs

Now that you've set up and tested the printer, you should make sure the LQ-2500 works with the application programs you want to use. If you're familiar with application programs and printer selection routines, simply consult the following table.

if you need more information on selecting a printer or sending commands from your application program, continue with this chapter. The last half of the chapter covers specific information on word processors, spreadsheets, graphics programs, and programming languages.

*Table 4 I. LQ-2.500 Printer Selection*

|   |   |
|---|---|
| First choice  | LQ-2500   |
| If the LO-2500 is not listed. select one of the other LQs In the order shown.   | LQ-1000<br>LQ-800<br>LQ1500   |
| Note:<br>If the program does not list any of the LQseries of printers, contact the manufacturer to find whether an update is available. |   |
| If an LO is not listed. select one of the printers in the order listed.   | EX<br>FX<br>Lx<br>RX<br>MX<br>Epson printer<br>Standard or<br>Draft printer |
| If you've installed the color option kit, choose:   | LQ-2500<br>"Ex800<br>● JX-80  |

\*Although you can print color text with the EX or JX drivers. graohrc pnnouts may be lengthened due to the difference between 9- and 24-pin printers.

---

---

## Choosing the Correct Printer

Most application programs let you specify the type of printer you're using, so that the program can take full advantage of the printer's features. Many programs provide an installation or setup section that presents a list of printers from which to choose. Table 4-1 lists the printers in order of preference.

### A quick test

After setting up your application program, you should print a sample document to be sure the program and the printer are communicating properly. If the document doesn't print the way you feel it should, recheck the program's printer selection and installation routine. If you're still having trouble printing, check the SelectType settings. Also consult the troubleshooting section in Appendix D.

---

## Computer-Printer Communication

Computers and printers communicate by using numerical codes to represent characters and commands. To be sure the two devices translate the characters in the same way, a standard code has been developed—the ASCII (American Standard Code for Information Interchange) code. Many application programs, in fact, specifically ask for ASCII codes to send printer commands.

The ASCII table, listed in Appendix B, includes codes for printable characters (letters, punctuation marks, numerals, and mathematical symbols). It also includes 33 other codes called control codes, that perform functions such as sounding the beeper and performing carriage returns. The 33 control codes, numbered from 0-31 and 127, are not enough to control all possible printer functions. So, most printer commands are actually a sequence of two **or** more codes.

The escape code, one of the 33 control codes (027), signals the beginning of a sequence of codes. This manual uses the ASCII abbreviation ESC for this code.



---

If you're using control codes to select printer functions for an application program or programming language, check the documentation. Different programs and languages use different methods of sending printer commands. The second half of this chapter covers this process more thoroughly

### Naming and using commands

In order to use printer commands, you should know how they are recognized by your application program. The most common way of naming codes or commands is with one of two numbering systems, decimal or hexadecimal.

The decimal system is the standard numbering system based on units of ten, using the numbers 0-9.

The hexadecimal, or hex, system is based on units of 16, and is often used by programmers. Instead of using only the numerals 0 through 9, the hex system also uses the fletters A through F. For example, the decimal numbers 9, 10, 11, and 12 are 09, 0A, 0B, and 0C in hex.

The most frequently used hexadecimal numbers lie in the range 0 to FF hex (0 to 255 in decimal). It's common to write hexadecimal numbers that are less than 16 with a zero in front.

In this book, hex numbers are distinguished from decimal numbers by the word hex after them (for example, 1B hex). Other common ways of denoting a hexadecimal number are:

1BH    \$1B    &1B    &H1B    <(1B>H

The Command Summary and the Quick Reference Card give both the decimal and hex numbers for each command.

---

## Setting Up Application Programs

Some application programs require nothing more than selecting the correct printer. Other programs, however, require specific information to take full advantage of a printer's features.

Because there are literally thousands of application programs available, only three general categories are addressed here: Word

---

Processors, Spreadsheets, and Graphics programs. In addition, a brief explanation of programming languages is also included at the end of the chapter.

---

## Word Processors

In many ways, word processors demand the most from your printer. When you create and print a document, you may change print styles and fonts, reformat pages, add headers and footers, and use bold, italic, and other effects.

The LQ-2500 is capable of producing a vast array of different print styles and effects, as shown in Chapter 5. However, you may have to spend some time working with your word processor to **take** full advantage of the LQ's capabilities.

### Installation or setup

The most important step in preparing your word processor is selecting the correct printer from Table 4-1. When you select a printer from a programs list of printers, you're actually selecting a printer *driver*. A printer driver contains specific commands and instructions that let your word processor use all of your printer's features and capabilities.

If **your** program doesn't have a selection (or driver) for the LQ-2500 (or another LQ), then you might have to select FX. Your LQ would still print, but because the FX has fewer features than the LQ **series**, your program could not take full advantage of the LQ. (**For** this reason, you should consider contacting the program manufacturer if the program doesn't list the LQ-2500 or another LQ.)

In the same installation section where you select a printer driver, some word processors also let you choose among various options. These options may include method of paper feed, type of interface, availability of graphics characters, and others. If you're having specific problems with printing, you may be able to solve them **by** checking these custom options.

---

## Initialization

Whenever you turn the power on for the LQ, an *initialization* sequence is performed that sets the printer to its default values (see Chapter 2 and Appendix E). Many word processors also send out an initialization command to reset the printer before printing.

This initialization, or reset command, is sent to ensure that unknown settings do not influence the information the program sends to the printer. Usually this shouldn't cause any problems. However, some programs may send a command that also resets any SelecType settings you've made (or settings made with a programming language).

For example, you may load a SelecType macro to print a document in Letter Quality Courier, on 14-inch paper. However, when you begin printing, the program reinitializes the printer, canceling the macro and resetting the printer to the program's default values.

Many word processors that send an initialization command also provide a way to either change it or take it out altogether. Check the program's installation or setup section to find whether you can modify the initialization command.

## SelecType

You have the choice of using the four preset SelecType macros, or creating your own. Two of the preset macros (1 and 2) for word processing.

Macro 1 is for producing documents in draft form, primarily because draft printing is quick. The macro prints in 10 pitch (pica) draft quality. The draft quality makes it fast, and 10 pitch makes it easy to read and edit.

After editing a document in draft, you could select macro 2 to print the document in Letter Quality Roman font. You can also create your own macro, or change the current settings for that specific job.

## Printer commands

The LQ-2500 is capable of many print styles, fonts, and enhancements. However, your word processor must tell the LQ when to use these various features by sending the proper printer commands.

---

Most word processors are not initially set up to send all of the commands you might want to use. Most of them have a key or sequence of keys, to send the bold command. Others may also underline. If you want to send other commands, perhaps for italic, or double-width, you'll probably have to set up your word processor accordingly.

Many programs allow you to assign commands to function keys (or a sequence of keys). When the key (or keys) is pressed, the command is then placed in the document. This is called *embedding* printer commands.

Although many word processors let you assign commands to various keys, most rely on you to find the correct command for the type of printing you want.

For example, if your word processor isn't set up for double-width printing, you would look up the LQ's command for double-width (ESC W 1) in the Command Summary. Once you've found the command, you would check your word processor's manual to find out how to send it.

Remember, if your LQ is not printing the way you think it should, check *both* the LQ and your word processor, and review this checklist:

- Make sure you've selected the correct printer.
- Carefully read the printer setup and installation information in your word processor's manual.
- Check the printer options that may be part of the installation or setup section (line feeds, interface, etc.).
- If your word processor cancels SelectType macros or other settings before printing, find out whether you can modify the program's initialization command.
- Make sure your word processor is capable of sending the proper commands to your printer.
- If you're still having difficulty printing, check the troubleshooting section in your word processor's manual, or in Appendix D of this manual.

---

## Spreadsheets

Although spreadsheets seldom use as many printing styles as word processors, they do have some very specific requirements.

### Installation and column width

If your spreadsheet program provides a list of printers, refer to Table 4-1 for the proper priority. If your spreadsheet doesn't have a printer setup routine, you should carefully read the program's manual for information on its printing facility.

A major concern when printing spreadsheets is the width of the printer. The LQ-2500 is a 136-column printer, which makes it particularly well-suited for spreadsheets. By combining modes and pitches with SelecType, you can have 68 to 272 printable columns (or characters), across a 14-inch page, as shown in Table 4-2.

Table 4-2. LQ-2500 Column Widths

| <b>Print Mode/Style</b>             | <b>Printable Columns</b> |
|-------------------------------------|--------------------------|
| 10 pitch + Double-width             | 68                       |
| 10 pitch + Condensed + Double-width | 116                      |
| 10 pitch                            | 136                      |
| 10 pitch + Condensed                | 233                      |
| 12 pitch + Double-width             | 81                       |
| 12 pitch + Double-width + Condensed | 136                      |
| 12 pitch                            | 163                      |
| 12 pitch + Condensed                | 272                      |
| 15 pitch + Double-width             | 102                      |
| 15 pitch                            | 204                      |

### Printer commands

Unlike word processors, spreadsheet programs don't usually let you place printer commands within a spreadsheet. Instead, one pitch or mode of printing is used for the whole spreadsheet. With the LQ-2500, there are three ways of sending commands to print a spreadsheet.

---

SelecType-You have the choice of using the four preset SelecType macros, or creating your own. One of those preset macros (macro 3) is for spreadsheets. It's set up to print in draft quality, condensed mode, with a right margin of 135 (for 136 columns).

The SelecType settings that have the greatest effect on spreadsheets are: Print Quality, Condensed, and Right Margin. (If your spreadsheet program seems to disregard the SelecType settings, see the section on Initialization.)

*The program's printing facility*-Almost all spreadsheets have the capability of sending commands to a printer. However, its usually up to you to pick the pitch or mode you want, then find the proper commands in the printer manual.

For example, your spreadsheet might send printer commands as a "setup string." To prepare a setup string for condensed, 12 pitch, you would look up the proper command in the LQ's Command Summary (Condensed, 12 pitch, gives the maximum number of printable characters per line, as shown in Table 4-2.)

The command for 12 pitch is ESC M, and the command for condensed is SI. Most spreadsheets want you to send the decimal equivalent for the command, also given in the Command Summary A setup string for condensed, 12 pitch, might look like this:

/027/077/015  
(MY M /SI)

Programs that ask you to set up the commands usually tell you how to do it; it's up to you to find the proper commands.

*A programming language*-Programming languages may be the most straightforward way of setting up a printer. As demonstrated in the section at the end of this chapter, you can simply send the appropriate command without going through a setup or installation program.

If you set up your printer with a programming language, such as BASIC or Pascal, be sure your spreadsheet program does not wipe out the settings with an initialization command, as described in the next section.

---

## Initialization

Like many word processors, some spreadsheet programs also send out an initialization command to reset the printer before printing.

This initialization, or reset command, is sent to ensure that unknown settings do not influence the information the program sends to the printer. Usually this shouldn't cause any problems. However, some programs may send a command that also resets SelecType settings (or settings made with a programming language).

For example, you may load a SelecType macro to print a spreadsheet in draft, condensed, with a right margin of 136. However, when printing begins, the program sends an initialization command that cancels the macro and resets the printer to the program's default values.

Although many word processors allow you to modify an initialization command, most spreadsheet programs don't. For these programs, you will have to rely on the programs own print features to send the proper commands.

If your spreadsheet is not printing the way you think it should, check *both* the LQ and your spreadsheet program, and review this checklist:

- If the program asks you to select a printer, be sure you have selected the correct one.
- Make sure the SelecType settings are correct.
- If the program is ignoring your SelecType settings, try sending print commands with the program's print facility
- If you're using the program's print facility recheck the LQ'S Command Summary to make sure you're sending the correct commands.
- If you're still having difficulty printing, check the troubleshooting section in your spreadsheet programs manual, or in Appendix D of this manual.

---

## Setting Up Graphics Programs

The LQ-2500 is capable of producing finely detailed graphic images in black or in color (with the optional color kit). Chapter 6 gives specific information on the graphics commands. However, the easiest way to take advantage of the LQ's capabilities is with one of the many graphics programs available.

### installation or setup

Most graphics programs have a printer selection routine, in which case you should check Table 4-1 for the proper priority. With graphics, however, it's even more important to select one of the LQ-series of printers. The LQs are 24pin printers, and consequently are capable of more detailed graphics than the FX or LX series, which are nine-pin printers.

### SekType and **character** tables

Any one of the four SelecType macros can be used with dot graphics programs, because most graphics programs send their own commands to print images dot by dot.

Preset macro 4 makes use of the Graphic character table, which uses *character* graphics for printing lines, corners, and shaded areas as shown in Chapter 2. For more information on selecting the character sets, see Chapters 2 and 5. The character tables are printed in Appendix B.



---

## Programming Languages

Most users rely on application programs to send commands to the printer. However, an awareness of programming languages can be helpful in exploring a printer's potential or troubleshooting a printing problem.

For example, you might want to set up your application program to send a command for italic printing. You can use a programming language, such as BASIC or Pascal, to do a quick printout before setting up the program.

Or, perhaps you've set up a program to send a certain command to the printer, but its not printing correctly You could send the same command with a programming language to find whether the problem lies with your application program, the command, or the printer,

### **Sending printer commands with BASIC**

You can send printer commands with any programming language. The examples in this manual are written in BASIC, because BASIC is included with most computer systems.

Most forms of BASIC use the LPRINT statement to send print commands and other output to the printer

To send individual printer commands, use the LPRINT statement and the CHR\$ function. For example, to send the command for italic, first check the LQ Command Summary for the proper command-W 4.

BASIC allows you to send commands in three different ways. If a printable character corresponds to the command (4 in the case of italic), then you can use that character, if it's enclosed in quotation marks:

```
LPRINT CHR$(27);"4"
```

Or, you can send the decimal or the hexadecimal equivalent of the command (Microsoft® BASIC requires that &H precede all hex codes):

```
LPRINT CHR$(27);CHR$(52);
```

**or**

```
LPRINT CHR$(&H1B) (&H34);
```

---

You can also use the LPRINT statement to send xjt to the printer, but it must be enclosed in quotation marks, as shown below.

```
LPRINT "This is a sample of italic."
```

To test the italic command, you would send:

```
10 LPRINT CHR$(27);"4";  
20 LPRINT "This is a sample of italic."
```

and see:

***This is a sample of italic.***

If you have a different version of BASIC, or a different programming language, consult the documentation.

## Using the LQ-2500 Print Features

This chapter describes the wide variety of fonts, print widths, styles, and enhancements available with the LQ-2500, including:

High-speed Draft  
Letter Quality  
**Emphasized**  
**Double-strike**  
*Italics*  
10 pitch  
12 pitch  
15 pitch  
Underlining  
D o u b l e - w i d t h  
Condensed  
**Superscript    S u b s c r i p t**  
**Proportional**

---

### Print Quality

The LQ-2500 has two levels of print quality: draft and Letter Quality. Draft printing is fast, making it ideal for rough drafts and editing work. Letter Quality takes a little longer to print, but produces fully formed characters for presentation-quality documents.

This is high-speed, draft quality printing.  
This is Letter Quality printing.

Because the LQ-2500 is a 24-pin printer, you can use all of the enhancements covered in this chapter with either draft or Letter Quality. Double-width, italic, emphasized, underlining, and other features can be used with either quality setting.

---

## selecting print quality

There are three easy methods of changing between draft and Letter Quality

- The control panel-With the printer on line, you can press the LQ button to select Letter Quality or the DRAFT button to select draft.

When you press the LQ button, the printer beeps twice and the display briefly flashes the current font, such as [ROMAN 1. The display then returns to 1 ON LINE1. (You can also select Letter Quality in other fonts with the LQ button-see the following section on Selecting Fonts.)

If you press the DRAFT button, you hear one beep, [DRAFT] is briefly displayed, then the [ON LINE1 message returns.

- SelecType-With the \*Change Macro mode, there are two ways of switching between Letter Quality and draft. You can simply change the current settings, or you can create and save a new macro containing either quality setting.

You can also send commands to switch between draft and Letter Quality with an application program or a programming language.

---

## Selecting Fonts

The LQ-2500 has five built-in Letter Quality fonts shown below. See Appendix C for complete printouts of each font.

- |                  |                                 |
|------------------|---------------------------------|
| 1. LQ Roman      | This is the Roman font.         |
| 2. LQ Sans Serif | This is the Sans Serif font.    |
| 3. LQ Courier    | This is the Courier font.       |
| 4. LQ Prestige   | This is the Prestige font.      |
| 5. LQ Script     | <i>This is the Script font.</i> |

---

All five fonts are available through SelecType, or with the LQ button. You can switch to draft quality from any of the fonts, but there is only one style of draft.

*Selecting fonts with the LQ button*-You can switch among the five fonts without having to go into SelecType. Pressing the LQ button while the printer is on line selects the current LQ font. The name of the font is displayed for a few seconds, then the f ON LINE1 message returns.

However, if you press the LQ button again, *while the current font name is displayed*, the name of the next font is displayed. Each pressing of the LQ button continues the rotation through the five fonts,

To select a font, press the LQ button until the font you want is displayed, then wait for the [ ON LINE1 message to return. The font you select then becomes the current setting.

Fonts selected with the LQ button temporarily override SelecType font settings. For example, you might load a macro that has the Courier font. If you decide to print in Sans Serif instead, you could simply use the LQ button to temporarily select the Sans Serif font. The next time you use the macro, Courier will still be installed. Selecting fonts with the LQ button doesn't change macro settings, it only overrides them until another setting or macro is selected.

*Selecting fonts with SelecType*-There are two ways to select a font with SelecType. You can include the font in a macro, or you can change the font in the current settings. SelecTypes \*Print Out Settings mode lets you check the fonts in the four macros, as well as the current font setting.

When you are selecting different fonts, be aware that *on&* the fonts change, not the pitch settings. Each font has designated pitches; to make the fonts look their best, they should be printed in these pitches. See the following section on Print Pitch and Character Width for a full explanation.

### Font cartridges

Additional fonts are available in font cartridges that plug into either connector in the option cartridge compartment. See your Epson dealer for more information on both of these options.

---

## Print Pitch and Character Width

To add greater variety to your documents, the LQ-2500 can print in three different pitches and perform proportional spacing. The SelecType Pitch setting lets you set the LQ accordingly.

The three pitches are: 10 characters per inch (pica), 12 characters per inch (elite), and 15 characters per inch. The following printout compares these three pitches.

```
This is 10 pitch--10 characters per inch.  
This is 12 pitch--12 characters per inch.  
This is 15 pitch--15 characters per inch.
```

As shown in the printout, 10 and 12 pitch characters are the same height. Characters in 15 pitch, however, are about two-thirds the height of 10 and 12 pitch characters. This makes 15 pitch particularly useful for footnotes, quotations, and any material you want to separate from the main document.

Proportional spacing varies the width of each letter, depending on whether it's a narrow letter, like an *i*, or a wide letter, like a *w*. The three pitches of 10, 12, and 15 change the width of *all* the characters equally. Proportional varies the width of *each* individual character, as shown in the following printout. Appendix B lists the proportional width tables.

```
This is lo-pitch spacing.  
This is proportional spacing.
```

Table 5-1 shows the designated pitches for each font. To make the fonts look their best, print them in their designated pitches.

You can print a font in a non-designated pitch, but the font won't look its best. For example, you can print the Roman font in 12 pitch, or Prestige in 10 pitch. The LQ-2500 adjusts the pitch accordingly but the spacing isn't as precise as a designated pitch.

---

Proportional spacing is the exception. Only the Roman and Sans Serif fonts have proportional spacing tables. If you select proportional for any other fonts, the printer will print in the selected font, but the results may be uneven.

*Table 5-1. Designated pitches and proportional spacing*

|             |     |                  |
|-------------|-----|------------------|
| Draft:      | 10. | 15               |
| Roman:      | 10. | 15, Proportional |
| Sans Serif: | 10. | 15, Proportional |
| Courier:    | 10. | 15               |
| Prestige:   | 12  |                  |
| Script:     | 10. | 15               |

### **Condensed and double-width**

In addition to the three pitches and proportional spacing, you can also use condensed and double-width to change character size, as shown in the following printout.

This condensed printing.

This is lo-pitch printing.

**T h i s i s d o u b l e - w i d t h .**

Condensed is useful for spreadsheets (see Chapter 4) and other applications where its necessary to print the maximum amount of information on a page. There's a separate SelecType setting for condensed to make it easier to print complete documents.

Double-width literally doubles the width of any character, as shown in the above printout. This character size is particularly effective for adding emphasis to titles and headings. To select double-width, use a

---

printer command sent from an application program or programming language.

Be aware that widening or narrowing characters also widens or narrows the spaces between words and letters. Word processors usually create a left margin by printing spaces. If you change character widths, you may need to adjust the number of characters on a line.

### **Special effects and emphasis**

The LQ-2500 offers two ways of emphasizing text. It **can also print** underlining, superscripts, and subscripts. These features are controlled by printer commands, but many application programs can produce them if the program is properly installed.

Emphasized and double-strike are the two modes that give added emphasis. In emphasized mode, the print head prints each dot twice as it moves across the paper. The second dot is printed slightly to the right of the first, producing darker, more fully formed characters.

In double-strike mode, the print head goes over each line twice, making the text bolder. The following examples compare emphasized and double-strike.

**Emphasized produces darker characters.**  
**Double-strike produces bolder characters.**

The underline mode provides an automatic way of fully underlining any piece of text, as shown below. It underlines spaces, subscripts, and superscripts without a break. Most word processors take advantage of this feature, but some programs use the underline character instead. If this happens, check your program for an underlining option.

**This is continuous underlining.**



Superscripts and subscripts can be used for printing footnote numbers and mathematical formulas. The example below shows underlining and superscripts and subscripts combined in a mathematical formula

$$\text{average} = \frac{a_1 + a_2 + \dots + a_n}{n}$$

---

## Using Character Tables and Sets

The LQ-2500 has *two built-in* methods of generating characters. One method uses the CC (Character Generator) Tables, the other method uses the characters stored in the international character sets.

### The CC tables

The CG Table setting in SelecType has three options: Italic, Graphic, and Download. To see the difference between the italic and Graphic character tables, refer to Appendix B.

The Graphic option gives you the greatest flexibility with most application programs, including word processors and spreadsheets. The Graphic option allows you, or the program you're using, to take advantage of Epson's Character Graphics set.

With character graphics, you can still use the different fonts, styles, and widths, but you also get graphics characters for charts, diagrams, and other uses. And you still get *italic* characters.

---

Some of the great things you can do .....

### Diagrams

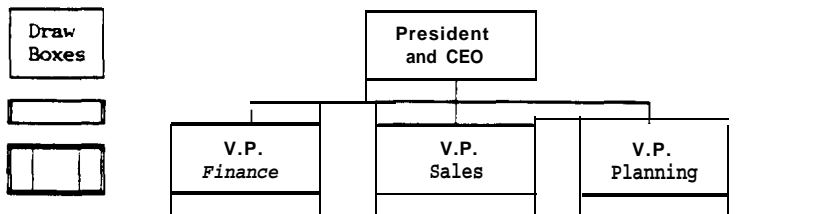

---

Although you won't see italic characters in the Graphic table, most application programs use ESC 4 and ESC 5 to turn italic on and off. This gives you italic with the Graphic option. (If your application program prints graphics characters when you **ask** for italic characters, then switch to the Italic character set.)

If you select the Epson Character Graphics set, you might need to choose a different printer from your program's printer installation routine (see Chapter 4). Your first choice should be the LQ-2500. The second choice should be the LQ-800/1000 printer equipped with the ESCP' identity module. This gives you the same character and command set found on the LQ-2500.

If neither of these printers is listed, you should contact the program's manufacturer to find whether an update is available. You could also select an Epson EX printer. It, too, has the same character set, **but be** aware that the EX is a nine-pin printer, not a 24-pin printer like the LQ-2500. This may result in a slightly different look to the characters.

The Download option is for future expansion,

#### **International characters**

The LQ-2500 also has the capability of printing characters of other languages. The SelecType Country setting lets you select from among 13 countries: USA, France, Germany, UK, Denmark 1, Sweden, Italy, Spain 1, Japan, Norway Denmark 2, Spain 2, and Latin America.

Table 5-2 shows the international characters printed in Letter **Quality**. See Appendix B for additional **tables**.

Table 5-2. International characters in Letter Quality

|               |    |    |    |    |    |    |    |    |     |     |     |     |
|---------------|----|----|----|----|----|----|----|----|-----|-----|-----|-----|
|               | 35 | 36 | 64 | 91 | 92 | 93 | 94 | 96 | 123 | 124 | 125 | 126 |
| USA           | #  | \$ | @  | [  | \  | ]  | ^  | '  | {   |     | }   | ~   |
| FRANCE        | #  | \$ | à  | ·  | ç  | š  | ^  | '  | é   | ù   | è   | ..  |
| GERMANY       | #  | \$ | š  | Ä  | Ö  | Ü  | ^  | '  | ä   | ö   | ü   | ß   |
| UK            | #  | \$ | @  | [  | \  | ]  | ^  | '  | {   |     | }   | ~   |
| DENMARK 1     | #  | \$ | @  | Æ  | Ø  | Å  | ^  | '  | æ   | ø   | å   | ~   |
| SWEDEN        | #  | ¤  | É  | Ä  | Ö  | Å  | Ü  | é  | ä   | ö   | å   | ü   |
| ITALY         | #  | \$ | @  | ·  | \  | é  | ^  | ù  | à   | ò   | è   | ì   |
| SPAIN 1       | ¤  | \$ | @  | ;  | Ñ  | ¿  | ^  | '  | ñ   | õ   | }   | ~   |
| JAPAN         | #  | \$ | @  | [  | ¥  | ]  | ^  | '  | {   |     | }   | ~   |
| NORWAY        | #  | ¤  | É  | Æ  | Ø  | Å  | Ü  | é  | æ   | ø   | å   | ü   |
| DENMARK 2     | #  | \$ | É  | Æ  | Ø  | Å  | Ü  | é  | æ   | ø   | å   | ü   |
| SPAIN2        | #  | \$ | á  | ;  | Ñ  | ¿  | é  | '  | í   | ñ   | ó   | ú   |
| LATIN AMERICA | #  | \$ | á  | ;  | Ñ  | ¿  | é  | ü  | í   | ñ   | ó   | ú   |

### The color option

If you've installed the color option kit, a printer command lets you select any of seven colors, including black. In addition, you can combine some of the basic colors to produce an even greater variety. Color can be used for graphics or text, and for a whole page or a single word.

With the color option kit, you can use either a black (#7756), **or** color (#7757) ribbon; the printer automatically detects the type of ribbon. You can use a black ribbon for ordinary printing, and save **your color** ribbon for special applications.

When a black ribbon is in use, or the color option kit has not been installed, the color commands are simply ignored. See the documentation packaged with the color option kit for complete information.

### Additional commands

The information in this chapter covers most of the features used in most printing applications, except for graphics and user-defined characters. These features are described in the next chapter.

The Command Summary describes additional commands for page formatting, such as margins, tabs, and line spacing. However, most of these functions are handled by application programs.

---

## Graphics and User-defined Characters

The dot graphics modes allow your LQ-2500 to produce pictures, graphs, charts, or almost any other pictorial material you can devise. The userdefined character feature allows you (or an application program) to put special characters in the LQ's memory so that they can be printed just as if they were ordinary letters or numbers.

Because many application programs use graphics, you may be able to print pictures and graphs like the ones on this page and the next by simply giving your program a few instructions.

The quickest and easiest way to print graphics on your LQ is to use a commercial graphics program. With such programs you usually create an image on your monitor and then give a command to send the image to the printer.

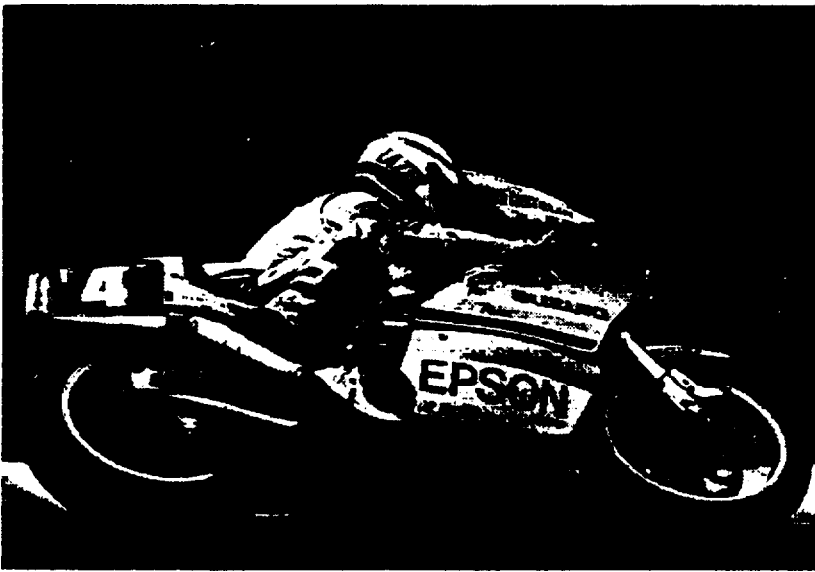

---

If you use an application program that produces graphics, or a package such as a spreadsheet that produces graphics, all you need to know about dot graphics is how to use the program. If, on the other hand, you wish to do your own programming or merely wish to understand how the LQ-2500 prints graphics, read on.

## Income Breakdown

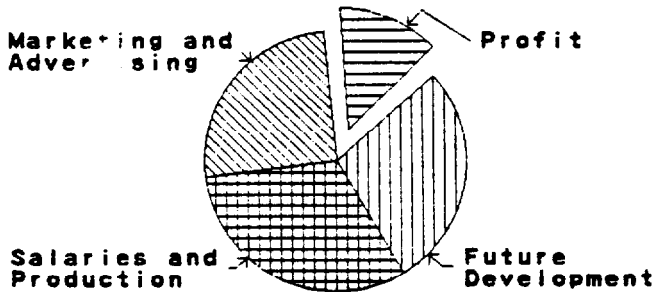

---

## The Print Head

To understand dot graphics you need to know a little about how the LQ's print head works.

The LQ's print head has 24 pins. As it moves across the page, electrical impulses cause the pins to fire, pressing the inked ribbon against the paper to produce a pattern of small dots. As the head moves across the paper, the pins fire time after time in different patterns to produce letters, numbers, or symbols.

Because the dots overlap each other both horizontally and vertically in the Letter Quality mode, it is difficult to see individual dots. Instead, the letters and symbols seem to be made of unbroken lines.

In order for the dots to overlap vertically the pins are arranged on the print head in more than one column. The intelligence of the printer handles the timing of pin firings so that the effect is that of 24 pins arranged in a single vertical column.

---

## **Dot patterns**

The LQ-2500 prints graphics the same way that pictures in newspapers and magazines are printed. If you look closely at a newspaper photograph, you can see that it is made up of many small dots. The LQ also forms its images with patterns of dots, as many as 360 dot positions per inch horizontally and 180 dots vertically. The images printed by the LQ can, therefore, be as finely detailed as the one on the first page of this chapter.

## **Eight-pin graphics**

The LQ has an eight-pin graphics mode with six densities, so that it is compatible with the many programs written for printers such as the Epson FX and RX series. Although this mode uses only one third of the LQ's pins, it produces good quality graphics and allows you to use the many programs written for eight-pin graphics.

## **Twenty-four-pin graphics**

The 24-pin graphics mode takes full advantage of the LQ's print head. It has five densities, but for simplicity this explanation covers only triple-density.

Triple-density prints up to 180 dots per inch horizontally. As the print head moves across the paper, every 1/180th of an inch it must receive instructions about which of its 24 pins to fire. At each position it can fire any number of pins from none to 24. This means that the printer must receive 24 bits of information for each column it prints. Since the LQ uses eight-bit bytes of information in its communication with a computer, it needs three bytes of information for each position.

## **Pin labels**

The graphics mode requires a method to tell the printer which pins to fire in each column. The software must send codes for the dot patterns; one number is needed for each column in a line. For each of those columns the print head prints the pattern of dots you have specified.

There are 256 possible combinations of eight pins, so a single number in the range 0-255 can be used to specify which of the patterns you want. In this system, one number is assigned to each pin as in Figure 6-1, on the following page.

To fire any one pin, you send its number. To fire more than one pin at the same time, add up the numbers of the pins and send the sum to the printer. With these labels for the pins, you fire the top pin by sending 128. To fire the bottom pin, you send 1. If you want to fire the top and bottom pins together, add 128 and 1, then send 129.

By adding the appropriate label numbers together, you can fire any combination of pins. Figure 62 shows three examples of how to calculate the number that will fire a particular pattern of pins.

With this numbering system, any combination of the eight pins adds up to a decimal number between 0 and 255, and no numbers are duplicated.

Since there are 24 pins in each column, you must make a calculation for each of the three sections in each column. As you can see, this method of planning and printing dot graphics requires considerable calculation. Because triple-density uses 180 columns per inch, printing a single line of triple-density graphics only one inch long requires 540 numbers. Fortunately commercial programs can do the calculations for you.

**Before** you can put these numbers in a graphics program, however, you need to know the format of the graphics command.

---

## Graphics Commands

The graphics m&e commands are quite different from the other commands covered so far in this manual. For most of the other modes,

---

Figure 6-1.  
pin numbering system

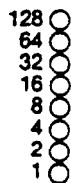

---

Figure 62.  
Calculations for pin patterns

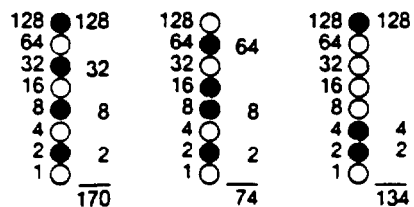

such as emphasized and double-width, one code turns the mode on and another turns it off. For graphics, the commands are more complicated because a code that turns on a graphics mode also specifies how many columns it will use. After the LQ-2500 receives this **code**, it interprets the next numbers as pin patterns and prints them on the paper.

The LQ has one command that allows you to use any of the 11 graphics options. The format of the command is:

ESCape =\*" **m nl n2 data**

In this command, m selects the graphics option and *nl* and *n2* specify the number of columns to reserve for graphics. The available graphics options are listed in Table 6-1.

*Table 61. Graphics Options*

| Option                    | Pins     | m        | Ho&. density (dots/in.) |
|---------------------------|----------|----------|-------------------------|
| Single-dens&              | 8        | 0        | <b>60</b>               |
| Double-density            | 0        | 1        | 120                     |
| Hiah-meed double-density' | <b>8</b> | <b>2</b> | <b>120</b>              |
| Quadruple-density'        | <b>8</b> | <b>3</b> | <b>240</b>              |
| CRT I                     | <b>8</b> | <b>4</b> | <b>80</b>               |
| CRT II                    | 8        | <b>6</b> | <b>90</b>               |
| Single-density            | 24       | 3 2      | 6 0                     |
| Double-density            | 2 4      | 3 3      | 1 2 0                   |
| CRT III                   | 2 4      | 3 8      | 9 0                     |
| Triple-density            | 2 4      | 3 9      | 1 8 0                   |
| Hex-density*              | 2 4      | 4 0      | 3 6 0                   |

'Adjacent dots cannot be panted In this mode

### Column reservation numbers

The graphics command requires more than one number to specify how many columns to reserve because one line can **use** thousands of columns, but the LQ **does** not **use** numbers **larger** than 255 (decimal).



---

Therefore, the graphics mode command uses two numbers for reserving columns.

To figure the number of columns reserved, multiply the second number by 256 and add it to the first number. Since the command is set up for two numbers, you must supply two numbers even if you need only one. When you need fewer than 256 columns, just make *nJ* the number of columns you are reserving and make *n2* a zero.

For example, if you wish to send 1632 columns of graphics data, *nl* should be 96 and *n2* should be 6 because  $1632 = 96 + (6 \times 256)$ .

The LQ will interpret the number of bytes determined by *nl* and *n2* as graphics data, no matter what codes they are. This means that you must be sure to supply enough bytes of graphics data or the LQ will stop and wait for more **data** and will seem to be locked. If, on the other hand, you supply too much graphics data, the excess will be interpreted and printed as regular text.

### First graphics program

This first program is a simple example to show you how the graphics command, column reservation numbers, and data can be used in a BASIC program. Type in and run the following program: be especially careful to include both semicolons. The program produces the printout **you see below** it.

```
10 WIDTH "LPT1:",255
20 LPRINT CHR$(27)+"CHR$(32) CHR$(40) CHR$(0);
30 FOR X=1 TO 120
40 LPRINT CHR$(1i'B);
50 NEXT X
```



Line 20 selects single-density 24-pin graphics (mode 32 from Table 6-1) and also reserves 40 columns for graphics. Since 24pin graphics requires three bytes of data for each column, line 30 begins a loop to supply 120 bytes of data. Line 40 contains the number 170 that produces the first pin pattern shown in Figure 6-2, and line 50 finishes the loop.

---

## Using handcalculated data to print graphics

You can now perform the simplest application of graphics-using hand-calculated data to print graphic images. While this method is the most tedious, it helps you understand dot graphics. Also, it is useful for small graphic elements that are used many times.

Figure 6-3 shows how you can use a grid to plan where you want dots to be printed. This grid represents a single line of graphics 42 columns long. Since each line of 24-pin graphics is approximately 1/8th of an inch high, and since triple-density graphics prints 180 dots per inch horizontally a design planned on this figure will be about 1/8th of an inch high and less than 1/4th of an inch wide.

The actual pattern that the LQ prints on the paper is made up of dots that overlap both vertically and horizontally. The planning grid uses an X for each dot, but remember that each X represents the center of a dot, and that the dots actually overlap each other.

---

*Figure 63.*  
*Pattern on grid*

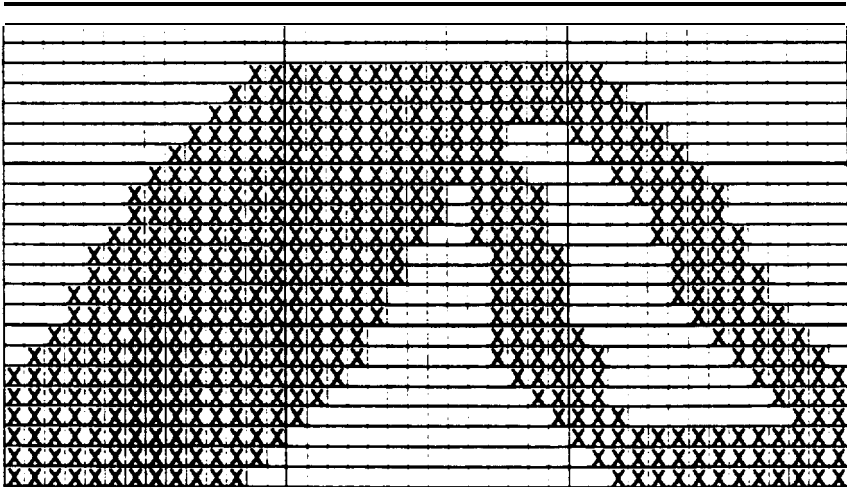



---

The following BASIC program prints the design shown in Figures 6-3 and 64. Notice that the **data** numbers in lines 80-140 are the same numbers that you see in Figure 64. Also note that the WIDTH statement in line 10 is for IBM@ PC BASIC; the format may be different for your system.

```
10 WIDTH "LPT1*"
20 iPRINT CHR$(27)"*" CHR$ (39) CHR$ (42) CHR $ (0);
30 FOR x=1 TO 126
40 READ N
50 LPRINT CHR$(N);
60 NEXT X
70 LPRINT
80 DATA 0,0,63,0,0,127,0,0,255,0,3,255~0~15J255~0~31~255
90 DATA 0, 127, 255, 0, 255, 255, 1, 255, 255, 3, 255, 255, 7, 255, 255, 15,
  255,255
100 DATA 31,255,254,31,255,252,31,255,24a,31,255,240,31,255,
  224,31,255,192
110 DATA 31,255,0,31,252,0,31,240,0,31,224,0,31,12a,0,31,240,0
120 DATA 31,255,192,28,255,224,28,127,240,28,15,248,38,8,252,
  31,0,=6
130 DATA 15,128,15,7,192,7,3,240,7,1,254,7,8,255,7,0,127,135
140 DATA 0,31,199,0,7,231,0,1,247,0,0,255,0,0,127,0,0163
```

In this program, line 20 assigns the graphics option (24-pin triple-density) with **code** 39. Code 42 sets the number of pin columns at 42. Lines 80-140 contain 126 **bytes** of data (42 pin columns x 3 bytes for each pin column). Lines 30-60 print the design shown below.

## A

Notice that the dots overlap quite a bit. This design was printed using the triple-density, 24-pin graphics option because the density is the same (180 **dots** to the inch) in both directions.

---

Adding the following lines to the previous program causes the pattern to print 10 times in a row as shown below.

```
15 FOR C=1 TO 10: RESTORE
65 NEXT C
```



### Individual graphics options commands

As previously mentioned, the LQ-2500 responds to commands that are also used by Epson FX and RX series printers. There are four individual graphics options commands that are very similar to the ESCape “\*” command, but each one works for only one graphics option. All these commands are for eight-pin graphics. Note that these commands contain one less variable than the ESCape “\*” command because they don’t need to select a graphics option. They are shown in Table 6-2.

*Table 62. individual graphics options commands*

| <b>Command</b> | <b>Function</b>               | <b>ESCape “*” Format</b> |
|----------------|-------------------------------|--------------------------|
| ESCape “K”     | Single-density                | ESCape “*” 0             |
| ESCape “L”     | Double-density                | ESCape “*” 1             |
| ESCape “Y”     | Double-density,<br>high-speed | ESCape “*” 2             |
| ESCape “Z”     | Quadruple-density             | ESCape “*” 3             |

### Reassigning command

The LQ has a command that allows you to change the graphics option assigned to any of the four individual graphics options commands. The command is:

ESCape “?. s m

The letter *s* represents the command that you wish to change the assignment for (K, L, Y, or Z) and *m* is the number of the graphics option (from Table 6-1) that you want to assign to it. For example, to change the ESCape ‘K’ command to use the CRT I screen graphics option, the command in BASIC is:

```
LPRINT CHR$(27)“?”;“i(“CHR$(I*)
```

---

This is a quick way to change the aspect ratio of the design that you are printing. Changing the graphics option will change the width without changing the height. You should, however, make this change with caution.

If you change one of the eight-pin graphics options to a 24-pin graphics option without changing the program that supplies the graphics data, you will print garbage (if the program prints at all). Remember, the 24-pin graphics options require three times as much graphics data as the eight-pin graphics options.

---

## User-defined Characters

With the LQ, it is possible to define and print characters of your own design. You can design an entirely new alphabet or typeface, **create** characters for special applications such as mathematical or scientific symbols, or create graphic patterns with user-defined characters to serve as building blocks for larger designs.

Below you can see samples of typefaces created with the userdefined character function.

**A B C D E F G H I J K L M N O P Q R S T U V W X Y Z**  
**A B C D E F G H I J K L M N O P Q R S T U V W X Y Z**

You can make the task of defining characters easier by using a commercial program that assists you in creating characters or simply supplies you with sets of characters already created. Also, some popular commercial programs take advantage of the LQ's userdefined character function to enhance printouts. (These characters are called download characters in some programs.)

The standard characters are stored in the LQ's Read Only Memory (ROM), and the user-defined characters are stored in the LQ's Random Access Memory (RAM).

---

## Design grids

Printing user-defined characters is like printing graphics patterns because you send the printer precise instructions on where you want each **dot** printed. In fact, planning a userdefined character is like planning a small graphics pattern.

To design a character you use a grid that 24 **dots** high-one dot for each wire on the LQ2500 print head. The **width** of the character matrix depends on the character set in use. For draft characters, the **grid is** nine dots wide.

For Letter Quality it is 29 dots wide, **and** for proportional characters it is 37 dots wide. The **dots** for both Letter Quality and proportional are spaced more closely together than those for draft.

Figure 65 shows the two design grids. The line at the side labelled **cap** indicates the top of a **standard** capital letter, **and** the line labelled **base** indicates the baseline for all letters except those with descenders (the bottom parts of such letters as j and y). The bottom row is usually left blank because it is used for underlining.

---

Figure 6-5.  
Design grids

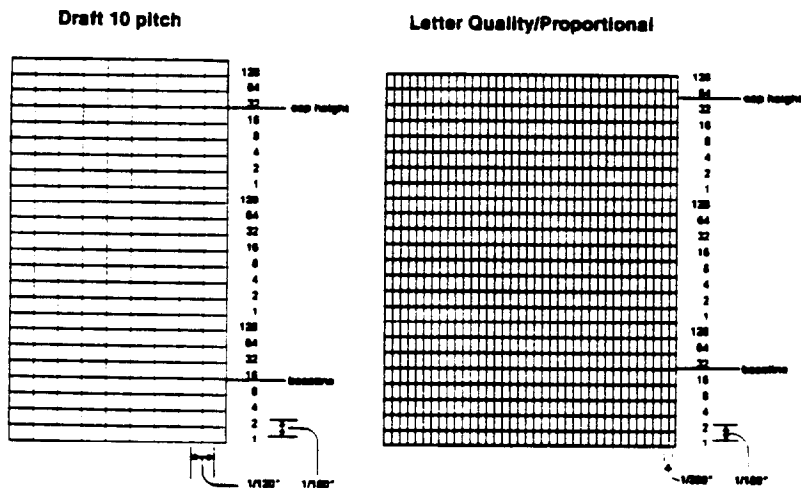

---

The grid on the right side of Figure 6-5 can be used for either Letter Quality or proportional characters. For Letter Quality you do not use all the columns. See Table 63 for further information.

There is one restriction in designing characters. Dots in the same row cannot print in adjacent columns-there must be an empty dot position to the left and to the right of each dot that prints. This is true in draft, Letter Quality and proportional.

---

## Defining Your Own Characters

The first step in defining characters is to place the dots on a grid just as you want them to print. The examples here, like the ones in the graphics section, use an X to represent each dot. Figure 6-6 shows a simple userdefined character on a draft grid.

Now translate the dot pattern created on the **paper** grid to a numeric format so you can **send the** information to the LQ2500. Every **dot has** an assigned value. Each vertical column (which has a maximum of **24** dots) is first divided into three groups of eight dots. Each group of eight **dots is** represented by one byte, which consists of eight bits. Hence, one bit represents each dot.

---

Figure 6-6.  
user-defined character

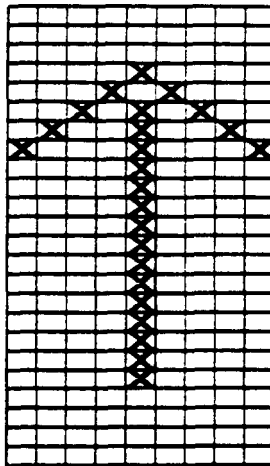



## Data numbers

The bits within each byte have values of 1, 2, 4, 8, 16, 32, 64, and 128. In the vertical column of dots, the bits are arranged so that the most significant bit (which has a value of 128) is at the top and the least significant bit (which has a value of 1) is at the bottom.

Figure 67 shows how to use this method to calculate the data numbers for the example character. On the left side of the figure the data numbers are calculated for the middle column. The value of each byte is calculated by adding the values of the rows where dots appear. The right side of the figure shows the whole character with the three data numbers for each column indicated at the bottom.

This manual uses decimal numbers because the example programs in this manual are written in BASIC. The data you send to the LQ2500, however, can be in any form (binary decimal, hexadecimal) that can be used with your programming language.

After you've designed a character on a grid and translated the dots to decimal equivalents, the last step is to send this information to the printer.

Figure 67.  
calculating the data

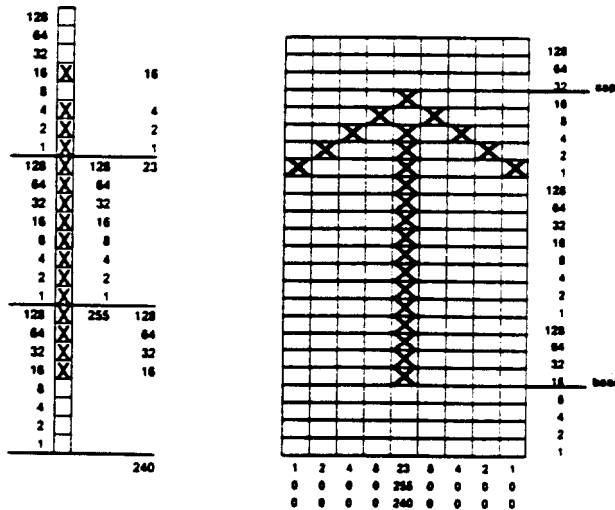

---

## Sending information to the LQ-2500

The printer loads characters in the print style (Letter Quality draft, or proportional) and font (Roman, Sans Serif, Courier, Prestige, or Script) that the printer is currently using. It also records whether italic or script (either superscript or subscript) is turned on. This means that if you want to print a character in the italic mode, for example, you must have the italic mode turned on when you define the character.

The command to define characters is one of the most complex in the LQ-2500s repertoire. The format of the command is:

ESCape ‘&’ 0 *nl n2 d0 dl d2* data

The EXape ‘&’ is simple enough. The 0 (which is ASCII code 0, not the numeral zero in quotation marks) allows for future enhancements. At this time it is always ASCII 0.

With the LQ, you can define many characters with a single command. The values *nl* and *n2* are the ASCII codes of the first and last characters you are defining. If you are defining only one character, *nl* and *n2* are the same. You can use any codes between 32 and 127 decimal for *nl* and *n2*, but it is best not to define decimal 32, which is the code for a space. Also, you can use letters in quotation marks instead of ASCII numbers for *nl* and *n2*.

For instance, if you wanted to redefine the characters A through Z, *nl* would be “A” (or ASCII code 65) and *n2* would be “Z” (or ASCII code 90). So the command ESCape ‘&’ 0 ‘AZ’ (followed by the appropriate data) would replace the entire alphabet of capital letters.

Following the specification of the range of characters to be defined are three data bytes (*d0-d2*) that specify the width of the character and the space around it. The left space (in dot columns) is specified by *d0*, and the right space is specified by *d2*. The second byte (*dl*) specifies the number of columns of dots that are printed to make up the character. By varying the width of the character itself and the spaces around it, you can create proportional-width characters that print at draft speed. Table 6-3 shows the maximum values for these bytes.

Table 6-3. Character width limits

|                          | <b>d1<br/>(maximum)</b> | <b>d0 + d1 + d2<br/>(maximum)</b> |
|--------------------------|-------------------------|-----------------------------------|
| Draft                    | 9                       | 12                                |
| Letter Quality, 10 pitch | 29                      | 36                                |
| Letter Quality, 12 pitch | 23                      | 30                                |
| Letter Quality, 15 pitch | 15                      | 24                                |
| Proportional             | 39                      | 42                                |

The last part of the character definition is the actual data that defines the dot patterns for each character. Since it takes three bytes to specify the dots in one vertical column of dots, the LQ-2500 expects **d1 x 3** bytes of data to follow d2.

An example character definition program should make this clear:

```

10 LRINT CHR$(27)"x0"
20 LPRINT CHRS(27)"&CHR$(0);
30 PRINT "@@?";
40 LPRINT CHR$(1)CHR$(9)CHR$(1);
50 FOR I=1 TO 27
60 READ A: LPRINT CHR$(A);
70 NEXT I
80 LF'RINT "@@!@"
90 LPRINT CHR$(27)"X"CHR$(1);
100 PRINT "#####"
110 LPRINT CHR$(27)"%"CHR$(0);
120 LPRINT "#####"
130 END
140 DATA 1,0,0,2,0,0,4,0,0
150 DATA 8,0,0,23,255,240,8,0,0
160 DATA 4,0,0,2,0,0,1,0,0,

```

In line 10, the ESCape ‘x0’ command selects draft quality printing.

The actual character definition starts in line 20. The two “at” signs (@) in line 30 represent **n1 and 172**, the range of characters being defined (in this case, a range of one). Line 40 contains dU, dI, and &.

---

The information about the actual character design (which is contained in the data statements at the end of the program) is sent to the printer in the loop between lines 50 and 70.

---

#### Note

When defining Letter Quality or proportional characters, put a WIDTH statement in your program to prevent carriage return and line feed codes from interfering with your definitions.

---

---

## Printing User-defined Characters

If you completed the example program above, you defined an arrow and placed it in the RAM location for ASCII code 64 (replacing the “at” sign). You can now print out a three-line sample of your work. The first and third lines (printed by lines 80 and 120 of the program) print the normal ‘at’ sign: the second line (line 100) prints the arrow that you defined. Run the program to see the printout below:

```
ls@@@ro
↑↑↑↑↑
@@@@@
```

As you can see, both sets of characters (the original ROM characters that the printer normally uses and the userdefined character set) remain in the printer available for your use. The command to switch between the two sets is used in lines 90 and 110. It is:

ESCape “%” n

If R is equal to 0, the normal ROM character set is selected (this is the default). If R is equal to 1, the user-defined character set is selected. If you select the user-defined character set before you have defined any characters, the command is ignored and the ROM characters are still used.

You may switch between character sets at any time—even in the middle of a line. To try it, place semicolons at the end of lines 80 and 100 in the program.

---

## Copying ROM to RAM

In many cases, you will want to redefine only a few of the characters to suit your needs, and keep the rest of the alphabet. As you have seen, it is possible to switch back and forth between the normal character set and the userdefined character set, but it's inconvenient.

Therefore, the LQ-2500 has a command which allows you to copy all of the standard characters from ROM to the user-defined character set. The command format is:

ESCape “:” 0 0 0

---

### Note

This command will cancel any user-defined characters you have created. You must send this command to the printer before you define characters.

---

If you use this command at the beginning of a program, define your special characters and select the user-defined character set. You can then print with the user-defined set as your normal character set. You'll never need to switch back and forth between sets.

### Letter Quality characters

If you select Letter Quality printing with the EC ‘xl’ command, you can design user-defined characters using up to 29 columns of the Letter Quality/Proportional grid. The dot columns are spaced closer together horizontally than draftquality dot columns (the horizontal dot spacing is 1/360th of an inch as opposed to 1/120th of an inch for draft characters).

### Proportional mode characters

Selecting the proportional character mode will yield user-defined characters of the highest resolution. Characters can be designed using all 37 columns of the Letter Quality/Proportional grid (see Figure 6-S).

Remember that in Letter Quality and proportional, as in draft, you cannot place dots in adjacent columns. There must be an empty dot position to the left and right of each dot that prints.

---

## Superscripts and subscripts

You can also create superscript and subscript user-defined characters. Just as Letter Quality characters are defined when the Letter Quality mode is selected, super/subscript characters are created when either superscript or subscript is selected.

These super/subscript characters can be used either as superscripts or as subscripts. The characters are exactly the same; it is only their placement that differs. The difference between super/subscript characters and regular characters is that they are smaller. They are a maximum of 16 dots high and their width in dot columns is shown in Table 6-4.

Table 64. Super/subscript widths

|                | $dI$<br>(maximum) | $dO + d1 + d2$<br>(maximum) |
|----------------|-------------------|-----------------------------|
| Draft          | 7                 | 12                          |
| Letter Quality | 23                | 36                          |
| Proportional   | 23                | 42                          |

Since super/subscript characters are smaller, they don't require as much information when you define them. When you define super/subscript characters, you need only two bytes of data for each vertical **row** of dots. Design grids for these characters are shown in Figure 6-g on the following page.

## Mixing print styles

Each of the three user-defined character modes (draft, Letter Quality and proportional) can be used in combination with most of the LQ-2500's various print styles, such as emphasized and double-width, but not with italic or super/subscript.

Mixing the three types of user-defined characters is not permitted. If, for example, you select draft and define some characters, then select proportional and define some more, the first character definitions will be destroyed. Only one type of character definition may be stored in RAM at any time.

If you define characters in one mode, such as draft, then switch to mother mode, such as Letter Quality, the command will be ignored and the *LQ* will print in the currently selected font. The user-defined character definitions, however, remain unaffected. If you switch back to the mode in which they were defined, you can then select and print them.

Keep in mind that user-defined characters are stored in RAM, which is not permanent. Whenever the printer power is turned off, all of the user-defined characters are lost. Also, your computer sometimes sends an initialization (INIT) signal, which wipes out all user-defined characters. (Some computers do this each time BASIC is loaded.) However, if you've saved your user-defined program correctly you can reload the new characters any time you want.

*Figure 6-8.*  
*Grids for super/subscript characters*

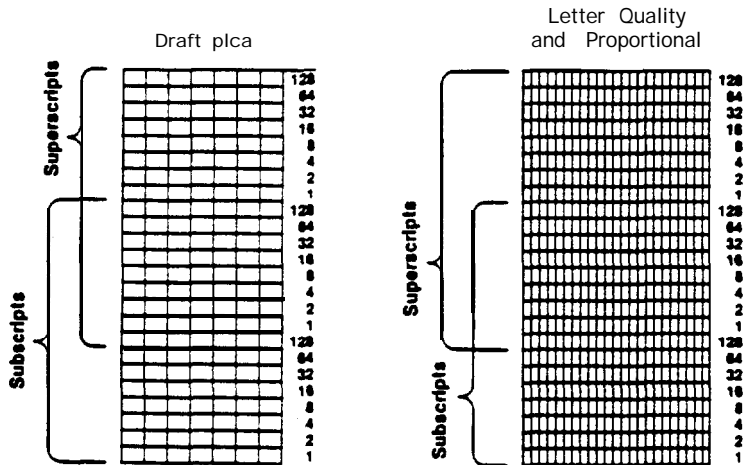

---

## Command Summary

This appendix lists and describes all the commands available on the LQ-2500. This summary is divided by topics, but there is a list of the commands in numerical order beginning on page A-4. If you know which command you are looking for, consult this list to find the page number where it is described.

The Quick Reference Card at the end of the book contains a list of the commands divided by topic, with page number references that direct you to full explanations of the commands.

The commands described in this appendix are divided into the following subjects:

|                                |                         |
|--------------------------------|-------------------------|
| Printer operation              | Print enhancement       |
| Data control                   | Word processing         |
| Vertical motion                | Character <b>tables</b> |
| Horizontal motion              | User-defined characters |
| Overall printing style         | Graphics                |
| Print size and character width |                         |

Each command has a Format section and a Comments section. The format section gives the ASCII, decimal, and hexadecimal codes for the command. The comments section describes the effect of the command and gives any additional information necessary for using it.

The format section includes:

|              |   |
|--------------|---|
| ASCII code:  | the sequence in standard ASCII characters |
| Decimal:     | the sequence in decimal numbers           |
| Hexadecimal: | the sequence in hexadecimal numbers       |



---

All three formats are equivalent, so you can pick the one best suited to **your** purpose. For instance, a BASIC programmer might refer to the first and second formats, a word processor might use the second, and a machine code programmer would use the third format. Variables are represented by italicized letters such as *n*, *n1*, *m*. The variables are explained in the comments section.

---

### Note

Some application programs make use of control key sequences. See the Control key chart on page A-3 of this appendix.

---

For the following commands that use only 0 or 1 for the variable, either the ASCII codes 0 and 1 or the ASCII characters 0 and 1 can be **used**:

Esc s, Esc u, Esc x, Esc p, ESC w, ESC s, ESC -, ESC %,  
ESC t, and ESC w

For example, in BASIC you can turn on double-width with either of these statements:

```
LPRINT CHR$(27);"W";CHRS(l)-ASCII Code
LPRINT CHR$(27);"W";"l "-ASCII Character
```

These **correspond to**:

ESC W SOH or EXW 1

### Examples

The simplest type of command consists of sending a single character to the printer. For instance, to print in condensed mode, you would send the code 15. The code format is:

ASCII code: SI  
Decimal: 15  
Hexadecimal: OF

---

More complex commands consist of two or more character codes. For example, to print in proportional mode the code format is:

ASCII code: ESC p *n*  
Decimal: 27 112 *n*  
Hexadecimal: 1B 70 *n*

In this case *n* can be either 1 or 0, to begin or end proportional printing. To turn ON proportional printing from BASIC the command would be:

```
LPRINT CHR%(27);CHR$( 112);CHR$( 1)
```

### Control key chart

Some application programs can use control key codes for decimal values 0-27. The table below gives you the proper values. The Control Key column indicates that you press the control key at the same time you press the key for the letter or symbol in that column. For example, you press the control key and A at the same time to send the value 1.

Some programs that use this system cannot use control-@, and many programs use the control keys for other purposes.

| Dec. | Hex. | Cntl. Key | Dec. | Hex. | Cntl. Key |
|------|------|-----------|------|------|-----------|
| 0    | 00   | @         | 14   | 0E   | N         |
| 2    | 02   | B         | 16   | 10   | O         |
| 2    | 0 2  | B         | 1 6  | 1 0  | P         |
| 3    | 0 3  | C         | 1 7  | 1 1  | Q         |
| 3    | 03   | D         | 18   | 12   |           |
| 5    | 05   | E         | 19   | 13   | S         |
| 6    | 06   | F         | 20   | 14   | T         |
| 7    | 07   |           | 21   | 15   | U         |
| 8    | 08   | H         | 22   | 16   | V         |
| 9    | 09   | I         | 23   | 17   | W         |
| 10   | 0A   | J         | 24   | 18   | X         |
| 11   | 0B   | K         | 25   | 19   | Y         |
| 12   | 0c   | L         | 26   | 1A   | Z         |
| 13   | 0D   | M         | 27   | 1B   | I         |

---

## Commands in Numerical Order

The following list shows control codes and ESCape sequences (with their decimal and hexadecimal values), and the page number where the complete command can be found.

| ASCII  | Dec. | Hex. | Description                               | Page  |
|--------|------|------|---|-------|
| BEL    | 7    | 07   | Beeper .....                              | A-1 1 |
| BS     | 8    | 08   | Backspace .....                           | A-18  |
| HT     | 9    | 09   | Tab Horizontally .....                    | A-20  |
| LF     | 10   | 0A   | Line Feed .....                           | A-14  |
| VT     | 11   | 0B   | Tab Vertically .....                      | A-1 6 |
| FF     | 12   | 0c   | Form Feed .....                           | A-12  |
| CR     | 13   | 0D   | Carriage Return .....                     | A-12  |
| s o    | 14   | 0E   | Select Double-width Mode (one line) . . . | A-25  |
| SI     | 15   | 0F   | Selet Condensed Mode .....                | A-24  |
| DC1    | 17   | 11   | Select Printer .....                      | A-7   |
| DC2    | 18   | 12   | Cancel Condensed Mode .....               | A-25  |
| DC3    | 19   | 13   | Deselect Printer .....                    | A-8   |
| DC4    | 20   | 14   | Cancel Double-width Mode (one line) ...   | A-26  |
| CAN    | 24   | 18   | Cancel Line .....                         | A-12  |
| DEL    | 127  | 7F   | Delete Character .....                    | A-8   |
| Esc so | 14   | 0E   | Select Double-width Mode (one line) ....  | A-25  |
| Esc SI | 15   | 0F   | Select Condensed Mode .....               | A-25  |
| ESC EM | 25   | 19   | Turn Auto Sheet Feeder Mode On/Off. ..    | A-10  |
| Esc SP | 32   | 20   | Set Intercharacter Space .....            | A-30  |
| Es !   |      | 21   | Master Select .....                       | A-22  |
| ESC”   | 35   | 23   | Cancel MSB Control .....                  | A-1 1 |
| EsC\$  | 36   | 24   | Set Absolute Print Position .....         | A-19  |
| Esc %  | 37   | 25   | Select User-defined Set .....             | A-32  |
| ESC&   | 38   | 26   | Define User-defined Characters .....      | A-32  |
| ESC*   | 42   | 2A   | Select Graphics Mode .....                | A-34  |
| Esc -  | 45   | 3D   | Turn Underlining On/Off .....             | A-29  |
| ESC/   | 47   | 2F   | Select Vertical Tab Channel .....         | A-1 7 |
| ESC 0  | 48   | 30   | Select 1 /&inch Line Spacing .....        | A- 14 |
| ESC 2  | 50   | 32   | Select 1/6-inch Line Spacing .....        | A-15  |
| ESC 3  | 51   | 33   | Select n/180-inch Line Spacing .....      | A-15  |
| ESc 4  | 52   | 34   | Select Italic Mode .....                  | A-31  |
| ESC 5  | 53   | 35   | Cancel Italic Mode .....                  | A-31  |
| ESC 6  | 54   | 36   | Enable Printable Characters .....         | A-33  |

---

| ASCII  | Dec. | Hex. | Description                                | Page  |
|--------|------|------|--|-------|
| ESC7   | 55   | 37   | Enable Upper Control Codes .....           | A-33  |
| Esc:   | 58   | 3A   | Copy ROM into RAM .....                    | A-32  |
| ESC<   | 60   | 3c   | Select Unidirectional Mode (one line) .... | A-9   |
| Esc =  | 61   | 3D   | SetMSB to 0 .....                          | A-10  |
| E-SC>  | 62   | 3E   | SetMSBto 1 .....                           | A-11  |
| ESC?   | 63   | 3F   | Reassign Graphics Mode .....               | A-35  |
| ESC @  | 64   | 40   | Initialize Printer .....                   | A-i   |
| ESCA   | 65   | 41   | Select n/60-inch Line Spacing .....        | A-15  |
| ESCB   | 66   | 42   | Set Vertical Tabs .....                    | A-16  |
| Esc c  | 67   | 43   | Select Page Length in Lines .....          | A-13  |
| Esc co | 67   | 43   | Select Page Length in Inches .....         | A-13  |
| ESC D  | 68   | 44   | Set Horizontal Tabs .....                  | A-20  |
| E X E  | 69   | 45   | Select Emphasized Mode .....               | A-26  |
| ESCF   | 70   | 46   | Cancel Emphasized Mode .....               | A-27  |
| ESCG   | 71   | 47   | Select Double-strike Mode .....            | A-27  |
| ESCH   | 72   | 48   | Cancel Double-strike Mode .....            | A-27  |
| ESCJ   | 74   | 4A   | Perform n/180-inch tine Feed .....         | A-1 6 |
| ESCK   | 75   | 4B   | Select Singledensity Graphics Mode ....    | A-33  |
| ESCL   | 76   | 4c   | Select Double-density Graphics Mode ...    | A-34  |
| ESCM   | 77   | 4D   | Select 12 Pitch (Elite) .....              | A-23  |
| ESCN   | 78   | 4E   | Set Skip-over-perforation .....            | A-1 3 |
| Esc 0  | 79   | 4F   | Cancel Skip-over-perforation .....         | A-1 4 |
| ESCP   | 80   | 50   | Select 10 Pitch (Pica) .....               | A-23  |
| ESC Q  | 81   | 51   | Set Right Margin .....                     | A-18  |
| ESCR   | 82   | 52   | Select an International Character Set .... | A-31  |
| Esc S0 | 83   | 53   | Select Superscript Mode .....              | A-28  |
| ESC S1 | 83   | 53   | Select Subscript Mode .....                | A-28  |
| ESC T  | 84   | 54   | Cancel Superscript/Subscript .....         | A-28  |
| Esc u  | 85   | 55   | Turn Unidirectional Mode On/Off .....      | A-9   |
| Esc w  | 87   | 57   | Turn Double-width Mode On/Off .....        | A-26  |
| ESCY   | 89   | 59   | Select High-speed Dbledensity Graphics ..  | A-34  |
| Esc z  | 90   | 5A   | Select Quadruple-density Graphics .....    | A-34  |
| Esc \  | 92   | 5C   | Set Relative Position .....                | A-19  |
| ESC a  | 97   | 61   | Select Letter Quality Justification .....  | A-29  |
| ESCb   | 98   | 62   | Set Vertical Tabs in Channels .....        | A-17  |
| Emi g  | 103  | 67   | Select 15 Pitch .....                      | A-23  |
| ESC k  | 107  | 6B   | Select Typestyle Family .....              | A-21  |

---

---

| ASCII | Dec. | Hex. | Description                              | Page |
|-------|------|------|--|------|
| ESC l | 108  | 6C   | Set Left Margin . . . . .                | A-17 |
| ESC p | 112  | 70   | Turn Proportional Mode On/Off . . . . .  | A-24 |
| ESC r | 114  | 72   | Select Printing Color . . . . .          | A-22 |
| ESC s | 115  | 73   | Turn Half-speed Mode On/Off . . . . .    | A-8  |
| ESC t | 116  | 74   | Select Character Table . . . . .         | A-30 |
| ESC x | 120  | 78   | Select Letter Quality or Draft . . . . . | A-21 |

---

## Epson ESC/P Commands

The following section lists and describes all the Epson IX/P commands.

---

### Printer Operation

#### Initialization

---

#### **E C @** **Initialize Printer**

Format:

ASCII code: ESC  
Decimal: 27 E  
Hexadecimal: 1B 40

Comments:

Resets the printer mode and clears the current print line preceding the command.

#### Selection

---

#### **DC1** **Select Printer**

Format:

ASCII code: DC1  
Decimal: 17  
Hexadecimal: 11

Comments:

Returns the printer to the selected state if it has been deselected by the printer deselect code (DC3). Does not select the printer if it has been switched off line by pressing the **ON LINE** button.

---

**DC3****Deselect Printer**

---

Format:

**ASCII code:** DC3  
Decimal: 19  
Hexadecimal: 13

Comments:

Puts the printer into the deselected state until select printer **code** (DCI) is received. The printer cannot be reselected with the **ON LINE** button.

**DEL****Delete Character**

---

Format:

**ASCII code:** DEL  
Decimal: 127  
Hexadecimal: 7F

Comments:

Removes the last text character on the print line **but does** not affect control codes.

**Speed****Escs****Turn Half-speed Mode On/Off**

---

Format:

|                    |            |            |          |
|--------------------|------------|------------|----------|
| <b>ASCII code:</b> | <b>ESC</b> |            | <i>n</i> |
| Decimal:           | <b>27</b>  | <b>1S5</b> | <i>n</i> |
| Hexadecimal:       | 1 B        | <b>73</b>  | <i>n</i> |

Comments:

The following values can be used for **n**:

- 1: Mode is turned ON.
- 0: Mode is turned OFF

---

## Printing direction

### **ESC <** Select Unidirectional Mode (one line)

---

Format:

ASCII code: ESC <  
Decimal: 27 60  
Hexadecimal: 1B 3C

Comments:

Printing is normally bidirectional. This command selects unidirectional printing for one line only (It is cancelled by a carriage return.) The print head moves to the extreme left (home) position, and printing takes place from left to right.

### **ESC u n** Turn Unidirectional Mode On/Off

---

Format:

ASCII code: ESC U n  
Decimal: 27 85 n  
Hexadecimal: 1B 55 n

Comments:

The following values can be **used** for **n**:

- 1: **Mde** is turned ON.
- 0: Mode is turned **OFF**

Printing is normally bidirectional. This command selects unidirectional printing for more accurate positioning during text or graphics printing.



---

**ESC EM****Turn Automatic Sheet Feed Mode On/Off**

---

Format:

|              |     |    |          |
|--------------|-----|----|----------|
| ASCII code:  | ESC | EM | <i>n</i> |
| Decimal:     | 27  | 25 | <i>n</i> |
| Hexadecimal: | 1B. | 19 | <i>n</i> |

Comments:

The following values can be used for *n*:

4: Mode is turned ON.

2: Loads sheet from bin 2.

1: Loads sheet from bin 1.

R: Ejects a sheet. (No paper is loaded from selected bin.)

0: Mode is turned OFF

The command should not be used unless the automatic sheet feeder is installed. It is ignored if any value other than 0, 1, 2, R, or 4 is used for *n*. The command can be used to override the SelectType setting.

Sheets are loaded (or changed) by a form feed (FE) command, or by line feeds past the end of the sheet. A normal 11-inch page holds 60 lines, the 61st line causes a new sheet to be loaded. Line feeds between the bottom of one page and the top of the next are ignored.

**MSB control**

**Note:** MSB is the Most Significant Bit. YSB control (ESC = , ESC >, and ESC ") does not work for graphics or user-defined characters.

**Esc = (equal)****Set MSB to 0**

---

Format:

|              |     |     |
|--------------|-----|-----|
| ASCII code:  | ESC |     |
| Decimal:     | 27  | s=1 |
| Hexadecimal: | 1B  | 3D  |

Comments:

Sets the MSB of all incoming data to 0. Some computers always send data with the MSB set to 1, which means that italics or character graphics will always be printed. ESC = can overcome this problem.

---

**Esc>****Set MSB to 1**

## Format:

ASCII code: ESC >  
Decimal: 27 62  
Hexadecimal: 1B 3E

## Comments:

Sets the MSB bit of all incoming data as 1.

**ESC”****Cancel MSB Control**

## Format:

ASCII code: ESC #  
Decimal: 27  
Hexadecimal: 1 B ; ;

## Comments:

Cancels the MSB control sit by ESC = or ESC >.

## Beep er

**BEL****Beeper**

## Format:

ASCII **code:** BEL  
Decimal: 7  
Hexadecimal: 07

## Comments:

Sounds the printer's **beeper**.

---

## Data Control

### CR

### Carriage Return

---

Format:

ASCII code: CR  
Decimal: 13  
Hexadecimal: OD

Comments:

Prints the data in the buffer and returns the print position to the left margin. A line feed may be added if AUTO LINE FEED = ON is set with SelecType, or if the AUTO FEED XT line on the parallel interface is held LOW.

### CAN

### Cancel Line

---

Format:

ASCII code: CAN  
Decimal: 24  
Hexadecimal: 18

Comments:

Removes all text on the print line, but does not affect control codes.

---

## Vertical Motion

### Form feeding

### FF

### Form Feed

---

Format:

ASCII code: FF  
Decimal: 12  
Hexadecimal: OC

Comments:

Prints the data in the print buffer and advances the paper to the top of the next form according to the current page length.

---

**ESCc****Set Page Length in Lines**

---

## Format:

|              |     |    |          |
|--------------|-----|----|----------|
| ASCII code:  | ESC | C  | R        |
| Decimal:     | 27  | 67 | <i>n</i> |
| Hexadecimal: | 1B  | 43 | <i>n</i> |

## Comments:

Sets the page length to *n* lines in the current line spacing. The value of *n* must be from 1-127 lines. The top of form position is set to the current line.

---

**ESC C0****Set Page Length in Inches**

---

## Format:

|              |     |    |    |          |
|--------------|-----|----|----|----------|
| ASCII code:  | ESC | C  | 0  | <i>n</i> |
| Decimal:     | 27  | 67 | 0  | <i>n</i> |
| Hexadecimal: | 1B  | 43 | 00 | <i>n</i> |

## Comments:

Sets the page length to *n* inches. The value of *n* must be from 1-22. The top of form position is set to the current line.

---

**ESCN****Set Skip-over-perforation**

---

## Format:

|              |     |    |          |
|--------------|-----|----|----------|
| ASCII code:  | ESC | N  | <i>n</i> |
| Decimal:     | 27  | 78 | <i>n</i> |
| Hexadecimal: | 1B  | 4E | <i>n</i> |

## Comments:

The variable *n* is the number of lines skipped between the last line printed on one page and the first line on the next page. For example, with the standard settings for line spacing (1/6-inch), and page length (66 lines), ESC N 6 prints 60 lines and then skips 6. The skip-over-perforation setting in SelecType performs the same function. This setting is cancelled by ESC C or ESC C 0. The value of *n* must be from 1-127.

---

**Esc 0****Cancel Skip-over-perforation**

---

Format:

|              |     |    |
|--------------|-----|----|
| ASCII code:  | ESC | 0  |
| Decimal:     | 27  | 79 |
| Hexadecimal: | 1B  | 4F |

Comments:

Cancels the skip-over-perforation set by ESC N. Overrides the skip over-perforation setting in SelecType.

**Line feeding**

---

**LF****Line Feed**

---

Format:

|                    |      |
|--------------------|------|
| ASCII <b>code:</b> | LF   |
| Decimal            | 10   |
| Hexadecimal:       | 0A . |

Comments:

When this command is received, the **data** in the print buffer is printed and the paper advances one line in the current line spacing.

---

**Esco****Select 1/8-inch Line Spacing**

---

Format:

|              |     |    |
|--------------|-----|----|
| ASCII code:  | ESC | 0  |
| Decimal:     | 27  | 48 |
| Hexadecimal: | 1B  | 30 |

Comments:

Sets the line spacing to 1/8 of an inch for subsequent line feed commands. The 0 is the digit zero and not ASCII code 0.

---

**ESC2****Select 1/6-inch Line Spacing**

---

## Format:

|              |     |    |
|--------------|-----|----|
| ASCII code:  | ESC | 2  |
| Decimal:     | 27  | 50 |
| Hexadecimal: | 1B  | 32 |

## Comments:

Sets the line spacing to 1/6 of an inch for subsequent line feed commands. The 2 is the digit two and not ASCII code 2. This is the default at power on.

**ESC3****Select  $n/180$ -inch Line Spacing**

---

## Format:

|              |     |    |     |
|--------------|-----|----|-----|
| ASCII code:  | ESC | 3  | $n$ |
| Decimal:     | 27  | 51 | $n$ |
| Hexadecimal: | 1B  | 33 | $n$ |

## Comments:

Sets the line spacing to  $n/180$  of an inch for subsequent line feed commands. The 3 is the digit three and not ASCII code 3. The value of  $n$  must be from 0-255.

**ESCA****Select  $n/604n$ ch Line Spacing**

---

## Format:

|              |     |    |     |
|--------------|-----|----|-----|
| ASCII code:  | ESC | A  | $n$ |
| Decimal:     | 27  | 65 | $n$ |
| Hexadecimal: | 1B  | 41 | $n$ |

## Comments:

Sets the line spacing to  $n/60$  of an inch for subsequent line feed commands. The value of  $n$  must be from 0-85.

---

**ESCJ**Perform  $n/180$ -4nch Line Feed

---

Format:

|              |     |    |     |
|--------------|-----|----|-----|
| ASCII code:  | ESC | J  | $n$ |
| Decimal:     | 27  | 74 | $n$ |
| Hexadecimal: | 1B  | 4A | $n$ |

Comments:

Advances the paper  $n/180$  of an inch. The value of  $n$  must be from 0-255. This command produces an immediate line feed but does not affect subsequent line spacing and does not produce a carriage return.

**Vertical tabbing**

---

**VT****Tab Vertically**

---

Format:

|              |           |
|--------------|-----------|
| ASCII code:  | <b>VT</b> |
| Decimal:     | 11        |
| Hexadecimal: | 0B        |

Comments:

Advances the paper to the next **tab** setting in the channel selected **by** ESC 1. If no channel has been **selected**, channel 0 is used. If no vertical tabs have been selected, the paper advances one line.

---

**ESCB****Set Vertical Tabs**

---

Format:

|              |     |    |      |      |     |     |     |    |
|--------------|-----|----|------|------|-----|-----|-----|----|
| ASCII code:  | ESC | B  | $n1$ | $n2$ | ... | ... | ... | 0  |
| Decimal:     | 27  | 66 | $n1$ | $n2$ | ... | ... | ... | 0  |
| Hexadecimal: | 1B  | 42 | $n1$ | $n2$ | ... | ... | ... | 00 |

Comments:

Sets up to 16 vertical tabs in the current line spacing. Tab settings are not affected by subsequent changes in line spacing. The tab settings are entered as  $n1$ ,  $n2$ , etc., all from 1-255, in ascending order. The ASCII code 0 indicates the end of the command. All settings are stored in channel 0 (see ESC b). ESC B 0 clears the tab settings.

---

## ESCb Set Vertical Tabs in Channels

---

Format:

ASCII code: ESC b c *n1 n2 ... .. 0*  
Decimal: 27 98 c *n1 n2 ... .. 0*  
Hexadecimal: 1B 62 c *n1 n2 ... .. 00*

Comments:

Functions the same as ESC B, except that the variable *c* selects a channel for the vertical tabs, which must be between O-7. Therefore, up to eight sets of vertical tabs can be set. The channels are selected by ESC/. To clear the tabs in channel *c* use ESC b c 0.

---

## ESC/ Select Vertical Tab Channel

---

Format:

ASCII code: ESC / c  
Decimal: 27 47 c  
Hexadecimal: 1B 2F c

Comments:

This command is used to select the vertical tab channel, with the value of *c* from O-7. All subsequent VT commands use the channel selected by this command.

---

## Horizontal Motion

### Margins

---

## ESC 1 Set Left Margin

---

Format:

ASCII code: ESC I *n*  
Decimal: 27 108 *n*  
Hexadecimal: 1B 6C *n*

Comments:

Sets the left margin to *n* columns in the current pitch, with the maximum value of *n* as follows: 134 in 10 pitch, 229 in condensed, 160 in 12 pitch, and 270 in condensed 12 pitch. Settings made in the proportional mode are treated as 10 pitch. This command clears previous tab settings **and** all previous characters in the print line. Use lowercase 1 (for left), not the numeral one. The minimum space between the margins is the width of one normal 10 pitch character.



## Format:

|              |              |            |          |          |
|--------------|--------------|------------|----------|----------|
| ASCII        | <b>code:</b> | <b>ESC</b> | <b>Q</b> | <i>n</i> |
| Decimal:     |              | 27         | 81       | <i>n</i> |
| Hexadecimal: |              | 1B         | 51       | <i>n</i> |

## Comments:

Sets the right margin to *n* columns in the current pitch. The maximum **value** of *n* is as follows: 136 in 10 pitch, 233 in condensed, 163 in 12 pitch, 272 in condensed 12 pitch and 204 in 15 pitch. Settings made in the proportional mode are treated as 10 pitch. This command clears previous **tab** settings and all previous characters in the print line. The minimum space between the margins is the width of one normal 10 pitch character.

**Print head movement****Bs****BacksDace**

---

## Format:

|              |              |           |
|--------------|--------------|-----------|
| ASCII        | <b>code:</b> | <b>BS</b> |
| Decimal:     |              | 8         |
| Hexadecimal: |              | 08        |

## Comments:

Prints out data in the print **buffer**, then moves the print position one space to the left. Backspacing can be performed up to, **but** not beyond, the left margin setting. The **BS code** is also ignored if ESC a, 2, or 3 has been sent. If this code is received immediately after graphics printing, the print position of subsequent data is moved back to the point at which graphics printing started.

---

**ESC \$****Set Absolute Print Position**

---

## Format:

|              |           |           |           |           |
|--------------|-----------|-----------|-----------|-----------|
| ASCII code:  | ESC       | \$        | <i>n1</i> | <i>n2</i> |
| Decimal:     | <b>27</b> | <b>36</b> | <i>n1</i> | <i>n2</i> |
| Hexadecimal: | 1B        | 24        | <i>n1</i> | <i>n2</i> |

## Comments:

This sequence specifies the distance from the left margin that subsequent characters are to **be** printed, using this formula: total number of **dots** = *n1* + (*n2* x 256). Each unit equals 1/60th of an inch. The sequence is ignored and the previous setting remains effective if the position specified is beyond the right margin.

**Esc \****Set Relative Position**

---

## Format:

|                    |            |           |           |           |
|--------------------|------------|-----------|-----------|-----------|
| <b>ASCII code:</b> | <b>ESC</b> |           | <i>n1</i> | <i>n2</i> |
| Decimal:           | <b>27</b>  | <b>92</b> | <i>n1</i> | <i>n2</i> |
| Hexadecimal:       | 1B         | 5C        | <i>n1</i> | <i>n2</i> |

## Comments:

Determines the position (relative to the current position) at which printing of following data will start. To find *n1* and *n2*, **first calculate** the displacement required in **dots**. If the displacement is to the left, subtract it from 65536. Send the resulting number using this formula: total number of dots = *n1* + (256 x *n2*). The command is ignored if it would move the print position outside the current margins. A unit is 1/120th of an inch in draft, and 1/180th of an inch in Letter Quality or proportional.

---

## Horizontal tabbing

**HT**

**Tab Horizontally**

---

Format:

ASCII code: HT  
Decimal: 9  
Hexadecimal: 09

Comments:

Advances the print position to the next horizontal **tab** setting. The default settings are at intervals of eight characters in the default pitch, and **tab** positions are not affected by subsequent changes in character pitch.

**ESC D**

**Set Horizontal Tabs**

---

Format:

ASCII **code:** **ESC D** *n1 n2 . . . 0*  
Decimal: **27 68** *n1 n2 ... ... 0*  
Hexadecimal: 1B 44 *n1 n2 ... ... 00*

Comments:

This command allows setting of up to 32 horizontal tabs, which are entered as *n1*, *n2*, *n3*, etc. (from 1-255) with the ASCII code 0 terminating the command. The tab settings must be entered in ascending order. ESC D 0 clears all tabs. The settings on power up or **after** an IX @ command are every eight characters. The tab settings do not change if the character pitch is changed, and for proportional printing the size of 10 pitch characters determines the tab positions.

---

---

## Overall Printing Style

### ESC x

### Select Letter Quality or Draft

Format:

|              |     |     |          |
|--------------|-----|-----|----------|
| ASCII code:  | ESC |     | <i>n</i> |
| Decimal:     | 27  | 120 | <i>n</i> |
| Hexadecimal: | 1B  | 78  | <i>n</i> |

Comments:

The following values can be used for *n*:

0: Selects the draft mode.

1: Selects the Letter Quality (LQ) mode.

### ESC k

### Select Typestyle Family

Format:

|              |     |     |          |
|--------------|-----|-----|----------|
| ASCII code:  | ESC | k   | <i>n</i> |
| Decimal:     | 27  | 107 | <i>n</i> |
| Hexadecimal: | 1B  | 6B  | <i>n</i> |

Comments:

This command affects only the Letter Quality typestyle, not draft.

If *n* = 0, the Roman typestyle in the printer is used. To select one of the four other type styles, use the family number of the font shown below. For example, to choose the Prestige font, use 3 for *n*.

The following values can be used for *n*:

0 = Roman

1 = Sans Serif

2 = Courier

3 = Prestige

4 = Script

---

**ESC r****Select Printing Color**

---

Format:

|              |           |            |          |
|--------------|-----------|------------|----------|
| ASCII code:  | ESC       |            | <i>n</i> |
| Decimal:     | <b>27</b> | <b>114</b> | <i>n</i> |
| Hexadecimal: | IB        | 72         | <i>n</i> |

Comments:

The variable *n* selects the printing color according to the table below.

**n Color**

|          |        |
|----------|--------|
| 0        | Black  |
| 1        | Red    |
| <b>2</b> | Blue   |
| 3        | Violet |
| <b>4</b> | Yellow |
| 5        | Orange |
| <b>6</b> | Green  |

---

**ESC !****Master Select**

---

Format:

|              |           |           |          |
|--------------|-----------|-----------|----------|
| ASCII code:  | ESC       | !         | <i>n</i> |
| Decimal:     | <b>27</b> | <b>33</b> | <i>n</i> |
| Hexadecimal: | IB        | 21        | <i>n</i> |

Comments:

Selects any valid combination of the following modes: 10 pitch, 12 pitch, proportional, condensed, emphasized, double-strike, double width, italic, and underline. See Appendix C for additional explanation.

---

## **Print Size and Character Width**

### **ESC P**

**Select 10 Pitch (Pica)**

**Format:**

ASCII code: ESC  
Decimal: 27 80  
Hexadecimal: 1B 50

**Comments:**

Selects IO pitch (10 characters per inch). Because 10 pitch is the default pitch, this command is normally used to cancel 12 pitch (elite), or I5 pitch.

### **ESC M**

**Select 12 Pitch (Elite)**

**Format:**

ASCII code: ESC M  
Decimal: 27 77  
Hexadecimal: 1B 4D

**Comments:**

Selects I2 pitch (12 characters **per** inch).

### **ESC g**

**Select 15 Pitch**

**Format:**

ASCII code: IX  
Decimal: 27 103  
Hexadecimal: 1B 67

**Comments:**

Selects 15 pitch (15 characters per inch), and cancels IO pitch or I2 pitch. Fifteen cannot be combined with condensed.

## Format:

|              |     |            |                 |
|--------------|-----|------------|-----------------|
| ASCII code:  | ESC |            | <i>n</i>        |
| Decimal:     | 27  | <b>112</b> | <b><i>n</i></b> |
| Hexadecimal: | 1B  | 70         | <b><i>n</i></b> |

## Comments:

The following values can be used for ***n***:

1: Mode is turned ON.

0: Mode is turned OFF

The width of proportional characters varies from character to character. Therefore, a narrow letter like *i* receives less space than a wide letter like *W*. The proportional widths are given in the character tables, which appear in Appendix B. This command overrides condensed.

## Format:

|              |    |
|--------------|----|
| ASCII code:  | SI |
| Decimal:     | 15 |
| Hexadecimal: | 0F |

## Comments:

Prints characters at about 60 per cent of their normal width. For example, the condensed 10 pitch mode has 17 characters per inch. Proportional mode cannot be condensed, and proportional will override condensed.

---

**ESC SI****Select Condensed Mode**

---

## Format:

|              |     |    |
|--------------|-----|----|
| ASCII code:  | ESC | SI |
| Decimal:     | 27  | 15 |
| Hexadecimal: | 1B  | 0F |

## Comments:

Duplicates the SI command.

**DC2****Cancel Condensed Mode**

---

## Format:

|              |     |
|--------------|-----|
| ASCII code:  | DC2 |
| Decimal:     | 18  |
| Hexadecimal: | 12  |

## Comments:

Cancels condensed printing set by SI, ESC SI, or SelecType.

**SO****Select Double-width Mode (one line)**

---

## Format:

|                    |           |
|--------------------|-----------|
| ASCII <b>code:</b> | <b>SO</b> |
| Decimal:           | 14        |
| Hexadecimal:       | 0E        |

## Comments:

Double-width mode doubles the width of all characters. This mode is canceled by a carriage return or DCd.

**ESC SO****Select Double-width Mode (one line)**

---

## Format:

|              |     |    |
|--------------|-----|----|
| ASCII code:  | ESC | SO |
| Decimal:     | 27  | 14 |
| Hexadecimal: | 1B  | 0E |

## Comments:

Duplicates the SO command.



---

**DC4****Cancel Double-width Mode (one line)**

---

## Format:

ASCII code: DC4  
Decimal: 20  
Hexadecimal: 14

## Comments:

Cancels one-line double-width printing selected by SO or ESC SO, but not double-width printing selected by ESC W or ESC !.

**ESC w****Turn Double-width Mode On/Off**

---

## Format:

ASCII code: ESC W *n*  
Decimal: 27 87 *n*  
Hexadecimal: 1B 57 *n*

## Comments:

The following values can be used for *n*:

1: Mode is turned ON.

0: Mode is turned OFF.

Double-width mode doubles the width of all characters.

---

**Print Enhancement****ESC E****Select Emphasized Mode**

---

## Format:

ASCII code: ESC E  
Decimal: 27 69  
Hexadecimal: 1B 45

## Comments:

Makes text bolder by printing each dot twice, with the second dot slightly to the right of the first.

---

**ESC F****Cancel Emphasized Mode**

---

Format:

|              |     |    |
|--------------|-----|----|
| ASCII code:  | ESC | F  |
| Decimal:     | 27  | 70 |
| Hexadecimal: | 1B  | 46 |

Comments:

Cancels emphasized, the mode selected by ESC E.

**ESC G****Select Double-strike Mode**

---

Format:

|              |     |    |
|--------------|-----|----|
| ASCII code:  | ESC | G  |
| Decimal:     | 27  | 71 |
| Hexadecimal: | 1B  | 47 |

Comments:

Makes text bolder by printing each line twice, with the second printing slightly below the first.

**ESC H****Cancel Double-strike Mode**

---

Format:

|              |     |    |
|--------------|-----|----|
| ASCII code:  | ESC | H  |
| Decimal:     | 27  | 72 |
| Hexadecimal: | 1B  | 48 |

Comments:

Turns off the double-strike mode selected by ESC G.

---

**ESC S 0****Select Superscript Mode**

---

**Format:**

|              |     |    |          |
|--------------|-----|----|----------|
| ASCII code:  | ESC | S  | <b>0</b> |
| Decimal:     | 27  | 83 | 0        |
| Hexadecimal: | 1B  | 53 | 0        |

**Comments:**

Prints characters about two-thirds of the normal character height in the upper part of the character space.

**ESCS 1****Select Subscript Mode**

---

**Format:**

|              |     |    |   |
|--------------|-----|----|---|
| ASCII code:  | ESC | S  | 1 |
| Decimal:     | 27  | 83 | 1 |
| Hexadecimal: | 1B  | 53 | 1 |

**Comments:**

Prints characters about two-thirds of the normal character height in the lower part of the character space.

**ESC T****Cancel Superscript/Subscript**

---

**Format:**

|              |     |    |
|--------------|-----|----|
| ASCII code:  | ESC | T  |
| Decimal:     | 27  | 84 |
| Hexadecimal: | 1B  | 54 |

**Comments:**

Cancels either superscript or subscript.

---

## ESC- Turn Underlining Mode On/Off

---

Format:

|              |           |           |                 |
|--------------|-----------|-----------|-----------------|
| ASCII code:  | ESC       | -         | <i>n</i>        |
| Decimal:     | <b>27</b> | <b>45</b> | <b><i>n</i></b> |
| Hexadecimal: | 1B        | 2D        | <b><i>n</i></b> |

Comments:

The following values can be used for ***n***:

- 1: Mode is turned ON.
- 0: Mode is turned OFF.

This mode provides continuous underlining, including spaces.

---

## Word Processing

### ESC a Select Letter Quality Justification

---

Format:

|              |           |           |                 |
|--------------|-----------|-----------|-----------------|
| ASCII code:  | ESC       |           | <i>n</i>        |
| Decimal:     | <b>27</b> | <b>97</b> | <b><i>n</i></b> |
| Hexadecimal: | 1B        | 61        | <b><i>n</i></b> |

Comments:

The following values can be used for ***n***:

- 0: Selects left justification.
- 1: Selects centering.
- 2: Selects right justification.
- 3: Selects full justification.

The default setting is ***n*** = 0. Full justification (***n*** = 3) is performed when the buffer becomes full or when the codes CR, G VT or ff are received. HT and BS are invalid except in ***n*** = 0 mode. For ***n*** = 3 there must be no carriage returns within a paragraph. Justification can be used in Letter Quality only not draft.

---

**ESC SP (space)****Set Intercharacter Space**

---

Format:

|              |     |    |          |
|--------------|-----|----|----------|
| ASCII code:  | ESC | SP | <i>n</i> |
| Decimal:     | 27  | 32 | <i>n</i> |
| Hexadecimal: | 1B  | 20 | <i>n</i> |

Comments:

Sets the amount of space added to the right of each character, in addition to the space already allowed in the design of the character. The number of dots is determined by *n*, which should be from 0-127. The space units are shown **below** in units of 1/100.

| MODE                         | UNITS |
|------------------------------|-------|
| Draft                        |       |
| 10cpi, 12cpi, 15cpi          | 120   |
| 10 cpi or 12 cpi condensed   | 240   |
| Letter Quality               |       |
| 10 cpi, 12cpi, 15cpi         | 180   |
| 10cpi or 12cpi condensed     | 360   |
| Proportional                 | 180   |
| Proportional super/subscript | 180   |
| Proportional condensed       | 360   |

---

**Character Tables****ESC t****Select Character Table**

---

Format:

|              |     |     |          |
|--------------|-----|-----|----------|
| ASCII code:  | ESC |     | <i>n</i> |
| Decimal:     | 27  | 116 | <i>n</i> |
| Hexadecimal: | 1 B | 74  | <i>n</i> |

Comments:

Selects the character table used by codes 128-255. Selecting Epson Character Graphics does not disable italic printing. Italic printing can still be selected by ESC 4. The following values can be used for *n*:

- 0: Selects Italic character table.
- 1: Selects Epson Graphic character **table**.

The characters '0' and '1' can also be used. The Italic and Epson Graphic character tables can also be selected with the SelectType CC Table function. See Appendix B for printouts of the tables.

---

**ESC 4****Select Italic Mode**

---

## Format:

|              |            |          |
|--------------|------------|----------|
| ASCII code:  | <b>ESC</b> | <b>4</b> |
| Decimal:     | 27         | 52       |
| Hexadecimal: | 1B         | 34       |

## Comments:

Causes characters from the italic character **table to** be printed. This command is valid even if the Epson Graphic set has been selected by ESC t or the SelecType CG Table function, **but** character graphics are not italicized.

---

**ESC 5****Cancel Italic Mode**

---

## Format:

|              |     |    |
|--------------|-----|----|
| ASCII code:  | ESC | 5  |
| Decimal:     | 27  | 53 |
| Hexadecimal: | 1B  | 35 |

## Comments:

Cancels the mode **selected** by ESC 4.

---

**ESC R****Select an International Character Set**

---

## Format:

|              |     |    |          |
|--------------|-----|----|----------|
| ASCII code:  | ESC | R  | <i>n</i> |
| Decimal:     | 27  | 82 | <i>n</i> |
| Hexadecimal: | 1B  | 52 | <i>n</i> |

## Comments:

Appendix B includes all the international character sets. The following values can be used for *n*:

|               |                    |
|---------------|--------------------|
| 0=USA         | i=Spain 1          |
| 1 = France    | 8 = Japan          |
| 2 = Germany   | 9 = Norway         |
| 3=UK          | 10 = Denmark 2     |
| 4 = Denmark I | 11=Spain2          |
| 5 = Sweden    | 12 = Latin America |
| 6 = Italy     |                    |

---

## User-defined Characters

**Note:** See Chapter 6 for sample programs and full information on this topic.

---

### **ESC&** Define User-defined Characters

Format:

|              |     |    |    |           |           |     |     |     |           |          |
|--------------|-----|----|----|-----------|-----------|-----|-----|-----|-----------|----------|
| ASCII code:  | ESC | &  | 0  | d1        | d2        | ... | ... | ... | <b>d</b>  | <b>n</b> |
| Decimal:     | 27  | 38 | 0  | <b>d1</b> | <b>d2</b> | ... | ... | ... | <b>dn</b> |          |
| Hexadecimal: | 1B  | 26 | 00 | <b>d1</b> | <b>d2</b> | ... | ... | ... | <b>dn</b> |          |

Comments:

This command allows characters to be redefined in the currently selected mode.

---

### **ESC:** Copy ROM into RAM

Format:

|              |     |    |    |    |    |
|--------------|-----|----|----|----|----|
| ASCII code:  | ESC | :  | 0  | 0  | 0  |
| Decimal:     | 27  | 58 | 0  | 0  | 0  |
| Hexadecimal: | 1B  | 3A | 00 | 00 | 00 |

Comments:

This code copies the characters in the ROM into RAM so that specific characters can be redefined.

---

### **ESC%** Select User-defined Set

Format:

|              |     |    |          |
|--------------|-----|----|----------|
| ASCII code:  | ESC | %  | <b>n</b> |
| Decimal:     | 27  | 37 | <b>n</b> |
| Hexadecimal: | 1B  | 25 | <b>n</b> |

Comments:

ESC & is required to define the character set. The following values can be used for **n**:

0: Selects the normal set.

1: Selects the user-defined set.

---

**ESC 6****Enable Printable Characters**

---

## Format:

|              |     |    |
|--------------|-----|----|
| ASCII code:  | ESC | 6  |
| Decimal:     | 27  | 54 |
| Hexadecimal: | 1B  | 36 |

## Comments:

When the Graphic character table is selected, this code enables the printing of codes 128 through 159 (decimal) as characters, not control codes.

**ESC 7****Enable Upper Control Codes**

---

## Format:

|              |     |    |
|--------------|-----|----|
| ASCII code:  | ESC | 7  |
| Decimal:     | 27  | 55 |
| Hexadecimal: | 1B  | 37 |

## Comments:

When the Graphic character table is selected, this code causes codes 128 through 159 to be treated as control codes. This is the default.

---

**Graphics**

**Note:** See Chapter 6 for sample graphics programs.  
See Table A-1 under ESC' for graphics modes.

**ESCK****Select Single-density Graphics Mode**

---

## Format:

|              |     |    |           |           |
|--------------|-----|----|-----------|-----------|
| ASCII code:  | ESC | K  | <i>n1</i> | <i>n2</i> |
| Decimal:     | 27  | 75 | <i>n1</i> | <i>n2</i> |
| Hexadecimal: | 1B  | 4B | <i>n1</i> | <i>n2</i> |

## Comments:

Turns on eight-pin, single-density graphics mode. The total number of columns = *n1* + (*n2* x 256).



---

## **ESC L** **Select Double-density Graphics Mode**

---

Format:

|              |     |    |           |           |
|--------------|-----|----|-----------|-----------|
| ASCII code:  | ESC | L  | <i>n1</i> | <i>n2</i> |
| Decimal:     | 27  | 76 | <i>n1</i> | <i>n2</i> |
| Hexadecimal: | 1B  | 4C | <i>n1</i> | <i>n2</i> |

Comments:

Turns on eight-pin, low-speed, double-density graphics mode. The total number of columns =  $n1 + (n2 \times 256)$ .

---

## **ESC Y** **Select High-speed Double-density Graphics Mode**

---

Format:

|              |     |    |           |           |
|--------------|-----|----|-----------|-----------|
| ASCII code:  | ESC | Y  | <i>n1</i> | <i>n2</i> |
| Decimal:     | 27  | 89 | <i>n1</i> | <i>n2</i> |
| Hexadecimal: | 1B  | 59 | <i>n1</i> | <i>n2</i> |

Comments:

Turns on eight-pin, high-speed, double-density graphics mode. The total number of columns =  $n1 + (n2 \times 256)$ .

---

## **Esc Z** **Select Quadruple-density Graphics Mode**

---

Format:

|              |     |    |           |           |           |
|--------------|-----|----|-----------|-----------|-----------|
| ASCII code:  | ESC |    | <i>n1</i> | <i>n2</i> |           |
| Decimal:     | 27  | 9: | <i>n1</i> | <i>n2</i> |           |
| Hexadecimal: | 1B  | 5A | <i>n</i>  | <i>1</i>  | <i>n2</i> |

Comments:

Turns on eight-pin, quadruple-density graphics mode. The total number of columns =  $n1 + (n2 \times 256)$ .

---

## **ESC \*** **Select Graphics Mode**

---

Format:

|              |     |    |          |           |           |
|--------------|-----|----|----------|-----------|-----------|
| ASCII code:  | ESC | *  | <i>m</i> | <i>n1</i> | <i>n2</i> |
| Decimal:     | 27  | 42 | <i>m</i> | <i>n1</i> | <i>n2</i> |
| Hexadecimal: | 1B  | 2A | <i>m</i> | <i>n1</i> | <i>n2</i> |

Comments:

Turns on graphics mode *m*. See Table A-1 below for details on the available modes. The total number of columns =  $n1 + (n2 \times 256)$ .

Table A-1. Graphics Modes

|                |    |          |            |
|----------------|----|----------|------------|
| CRT I          | 8  | <b>4</b> | 80         |
| CRT II         | a  | 6        | 90         |
| Sinle-density  | 24 | 32       | 60         |
| Double-density | 24 | 33       | 120        |
| CRT III        | 24 | 38       | 90         |
| Triple-density | 24 | 39       | <b>180</b> |
| Hex-density'   | 24 | 40       | 360        |

'Adjacent dots cannot be printed in this mode

## ESC ?

## Reassign Graphics Mode

Format:

ASCII code: ESC ? s **n**  
 Decimal: 27 63 **s** **n**  
 Hexadecimal: 1B 3F s **n**

Comments:

Changes one graphics mode to another. The variable is a character (K, L, Y or Z), which is reassigned to a mode *n* (0-6).

## ASCII Conversion Chart and Character Tables

This appendix contains an ASCII conversion chart, the LQ-2500 character sets in Roman font only and proportional width tables. See Appendix C for representations of San Serif, Prestige, Courier, and Script character sets.

---

### ASCII Conversion Chart

| Decimal | Hexadecimal | Abbreviation       | Control key |
|---------|-------------|--------------------|-------------|
| 0       | 00          | ( N W              | Control-@   |
|         | 01          | (SOH)              | Control-A   |
| 1       | 02          | (s-m)              | Control-B   |
| 3       | 03          | <b>&lt;ETX&gt;</b> | Control-C   |
|         | 04          | <b>&lt;EOT&gt;</b> | Control-D   |
| 5       | 05          | <b>&lt;ENQ&gt;</b> | Control-E   |
| 6       | 06          | (ACK)              | Control-F   |
| 7       | 07          | (BEL)              | Control-G   |
| a       | 08          | (BS)               | Control-H   |
| 9       | 09          | <HT>               | Control-I   |
| 10      | 0A          | (LF)               | Control-J   |
| 11      | 0B          | (VT)               | Control-K   |
| 12      | 0C          | (ff)               | Control-L   |
| 13      | 0D          | (CR)               | Control-M   |
| 14      | 0E          | (SO)               | Control-N   |
| 15      | 0F          | (SI)               | Control-O   |
| 16      | 10          | <b>(DLE)</b>       | Control-P   |
| 17      | 11          | <b>&lt;Da&gt;</b>  | Control-Q   |
| 18      | 12          | <b>(DC2)</b>       | Control-R   |
| 19      | 13          | <DC3>              | Control-S   |
| 20      | 14          | <DC4>              | Control-T   |
| 21      | 15          | <NAK>              | Control-U   |
| 22      | 16          | <SYN>              | Control-V   |
| 23      | 17          | <Em>               | Control-W   |
| 24      | 18          | <CAN>              | Control-X   |
| 25      | 19          | <EM>               | Control-Y   |
| 26      | 1A          | <SUB>              | Control-Z   |
| 27      | 1B          | <ESC>              | Control-(   |
| 28      | 1C          | <F-5>              |             |
| 29      | 1D          | <GS>               |             |
| 30      | 1E          | <RS>               |             |
| 31      | 1F          | <US>               |             |
| 32      | 20          | <SP>               |             |

| Decimal | Hexadecimal | Character | Decimal | Hexadecimal | Character |
|---------|-------------|-----------|---------|-------------|-----------|
| 33      | 21          | !         | 81      | 51          | Q         |
| 34      | 22          | "         | 82      | 52          | R         |
|         | 23          | #         | 83      | 53          | S         |
| 36      | 24          | \$        |         | 54          | T         |
| 37      | 25          | %         | 85      | 55          | u         |
| 38      | 26          | &         | 86      | 56          | V         |
| 39      | 27          | '         | 87      | 57          | W         |
| 40      | 28          | (         | 88      | 58          | X         |
| 41      | 29          | )         | 89      | 59          | Y         |
| 42      | 2A          | *         |         | 5A          | Z         |
| 43      | 2B          | +         | 91      | 5B          | [         |
| 44      | 2c          | ,         | 92      | 5C          | \         |
| 45      | 2D          | -         | 93      | SD          | ]         |
| 46      | 2E          | .         | 94      | 5E          | A         |
| 47      | 2F          | /         | 95      | 5F          | -         |
| 48      | 30          | 0         | 96      | 60          |           |
| 49      | 31          | 1         | 97      | 61          |           |
| 50      | 32          | 2         | 98      | 62          | :         |
| 51      | 33          | 3         | 99      | 63          |           |
| 52      | 34          | 4         | 100     | 64          | :         |
| 53      | 35          | 5         | 101     | 65          | e         |
| 54      | 36          | 6         | 102     | 66          | f         |
| 55      |             | 7         | 103     | 67          |           |
| 56      | 38          | 8         | 104     |             | E         |
| 57      | 39          | 9         | 105     | 69          | i         |
| 58      | 3A          | :         | 106     | 6A          |           |
| 59      | 3B          | ;         | 107     | 6B          | i         |
| 60      | 3c          | <         | 108     |             | l         |
| 61      | 3D          | =         | 109     | 6C          | m         |
| 62      | 3E          | >         | 110     | 6E          | n         |
| 63      | 3F          | ?         | 111     | 6F          | o         |
| 64      | 40          | @         | 112     | 70          | p         |
| 65      | 41          | A         | 113     | 71          | q         |
| 66      | 42          | B         | 114     | 72          | r         |
| 67      | 43          | C         | 115     | 73          | s         |
| 68      | 44          | D         | 116     | 74          | t         |
| 69      | 45          | E         | 117     | 75          | u         |
| 70      | 46          | F         | 118     | 76          | v         |
| 71      | 47          | G         | 119     | 77          | w         |
| 72      | 48          | H         | 120     | 78          | x         |
| 73      | 49          | I         | 121     | 79          | Y         |
| 74      | -1A         | J         | 122     | 7A          |           |
| 75      | 4B          | K         | 123     | 7B          | {         |
| 76      | 4C          | L         | 124     | 7c          |           |
| 77      | 4D          | M         | 125     | 7D          | }         |
| 78      | 4E          | N         | 126     | 7E          |           |
| 79      | 4F          | O         | 127     | 7F          | (DEL)     |
| 80      | 50          | P         |         |             |           |

---

## International Character Sets-Draft

|                 |    |    |   |   |   |   |   |   |   |   |   |   |
|-----------------|----|----|---|---|---|---|---|---|---|---|---|---|
| USA             | #  | \$ | @ | [ | \ | ] | ^ | ' | { |   | } | ~ |
| France          | #  | \$ | à | • | ç | š | ^ | ' | é | ù | è | ˆ |
| Germany         | #  | \$ | š | À | Ö | Ü | ^ | ' | ä | ö | ü | ß |
| UK              | f  | \$ | @ | [ | \ | ] | ^ | ' | { |   | } | ~ |
| Denmark I       | #  | \$ | @ | Æ | Ø | Å | ^ | ' | æ | ø | å | ˆ |
| Sweden          | #  | ¤  | É | Ä | Ö | Å | ^ | Ü | é | ä | ö | å |
| Italy           | St | \$ | @ | • | \ | é | ^ | Ü | à | ò | è | ì |
| Spain           | Pt | \$ | @ | ; | Ñ | ¿ | ^ | ' | ñ | ~ | } | ˆ |
| Japan           | #  | \$ | @ | [ | ¥ | ] | ^ | ' | { |   | } | ~ |
| M M Y           | t  | ¤  | É | Æ | Ø | Å | ^ | Ü | é | æ | ø | å |
| Denmark II      | ll | \$ | É | Æ | Ø | Å | ^ | Ü | é | æ | ø | å |
| Spain II        | #  | \$ | á | ; | Ñ | ¿ | ^ | ' | í | ñ | ó | ú |
| Latin P4neric.a | 8  | \$ | á | ; | Ñ | ¿ | ^ | ' | í | ñ | ó | ú |

---

## International Character Sets-Letter Quality

|                  |   |    |   |   |   |   |   |   |   |   |   |   |
|------------------|---|----|---|---|---|---|---|---|---|---|---|---|
| USA              | # | \$ | @ | [ | \ | ] | ^ | ' | { |   | } | ~ |
| France           | # | \$ | à | • | ç | š | ^ | ' | é | ù | è | ˆ |
| Germany          | # | \$ | š | À | Ö | Ü | ^ | ' | ä | ö | ü | ß |
| UK               | # | \$ | @ | [ | \ | ] | ^ | ' | { |   | } | ~ |
| Denmark          | # | \$ | @ | Æ | Ø | Å | ^ | ' | æ | ø | å | ˆ |
| Sweden           | # | ¤  | É | Ä | Ö | Å | ^ | Ü | é | ä | ö | å |
| Italy            | # | \$ | @ | • | \ | é | ^ | Ü | à | ò | è | ì |
| Spain            | # | \$ | @ | ; | Ñ | ¿ | ^ | ' | ñ | ~ | } | ˆ |
| Japan            | # | \$ | @ | [ | ¥ | ] | ^ | ' | { |   | } | ~ |
| Norway           | # | ¤  | É | Æ | Ø | Å | ^ | Ü | é | æ | ø | å |
| <b>Denmark11</b> | # | \$ | É | Æ | Ø | Å | ^ | Ü | é | æ | ø | å |
| Spain II         | # | \$ | á | ; | Ñ | ¿ | ^ | ' | í | ñ | ó | ú |
| Latin America    | # | \$ | á | ; | Ñ | ¿ | ^ | ' | í | ñ | ó | ú |

---

## How to Use the Charts

To determine the hexadecimal number that prints a particular character, find the character in one of the tables; then look at the top of its column and at the beginning of its row. The number at the top of the column is the first digit of the character's hex code, and the number at the beginning of the row is the second digit of the hex code.

For example, find the capital Z in the Epson **Draft** chart on the next page. At the top of its column is 5 and at the beginning of its row is A. Therefore the hex code for a capital Z is 5A.

### Converting hexadecimal numbers to decimal numbers

If you prefer to use decimal numbers instead of hexadecimal numbers, you can convert them with the chart below. Just read down in the column for the first digit of the hex number and across in the row for the second digit. Where the two intersect is the decimal number that corresponds to your hex number. For example, to find the decimal equivalent of hex 5A, look where column 5 intersects with row A. There you will find decimal 90.

#### *Hex-tuilecimal Conversion Chart*

|   | 0  | 1  | 2  | 3  | 4  | 5  | 6   | 7   | 8   | 9   | A   | B   | C   | D   | E   | F   |
|---|----|----|----|----|----|----|-----|-----|-----|-----|-----|-----|-----|-----|-----|-----|
| 0 | 0  | 16 | 32 | 48 | 64 | 80 | 96  | 112 | 128 | 144 | 160 | 176 | 192 | 208 | 224 | 240 |
| 1 | 1  | 17 | 33 | 49 | 65 | 81 | 97  | 113 | 129 | 145 | 161 | 177 | 193 | 209 | 225 | 241 |
| 2 | 2  | 18 | 34 | 50 | 66 | 82 | 98  | 114 | 130 | 146 | 162 | 178 | 194 | 210 | 226 | 242 |
| 3 | 3  | 19 | 35 | 51 | 67 | 83 | 99  | 115 | 131 | 147 | 163 | 179 | 195 | 211 | 227 | 243 |
| 4 | 4  | 20 | 36 | 52 | 68 | 84 | 100 | 116 | 132 | 148 | 164 | 180 | 196 | 212 | 228 | 244 |
| 5 | 5  | 21 | 37 | 53 | 69 | 85 | 101 | 117 | 133 | 149 | 165 | 181 | 197 | 213 | 229 | 245 |
| 6 | 6  | 22 | 38 | 54 | 70 | 86 | 102 | 118 | 134 | 150 | 166 | 182 | 198 | 214 | 230 | 246 |
| 7 | 7  | 23 | 39 | 55 | 71 | 87 | 103 | 119 | 135 | 151 | 167 | 183 | 199 | 215 | 231 | 247 |
| 8 | 8  | 24 | 40 | 56 | 72 | 88 | 104 | 120 | 136 | 152 | 168 | 184 | 200 | 216 | 232 | 248 |
| 9 | 9  | 25 | 41 | 57 | 73 | 89 | 105 | 121 | 137 | 153 | 169 | 185 | 201 | 217 | 233 | 249 |
| A | 10 | 26 | 42 | 58 | 74 | 90 | 106 | 122 | 138 | 154 | 170 | 186 | 202 | 218 | 234 | 250 |
| B | 11 | 27 | 43 | 59 | 75 | 91 | 107 | 123 | 139 | 155 | 171 | 187 | 203 | 219 | 235 | 251 |
| C | 12 | 28 | 44 | 60 | 76 | 92 | 108 | 124 | 140 | 156 | 172 | 188 | 204 | 220 | 236 | 252 |
| D | 13 | 29 | 45 | 61 | 77 | 93 | 109 | 125 | 141 | 157 | 173 | 189 | 205 | 221 | 237 | 253 |
| E | 14 | 30 | 46 | 62 | 78 | 94 | 110 | 126 | 142 | 158 | 174 | 190 | 206 | 222 | 238 | 254 |
| F | 15 | 31 | 47 | 63 | 79 | 95 | 111 | 127 | 143 | 159 | 175 | 191 | 207 | 223 | 239 | 255 |

## Epson Italics Character Set-Draft

|    | 0 | 1  | 2 | 3 | 4 | 5 | 6 | 7 | 8  | 9 | A | B | C | D | E | F |
|----|---|----|---|---|---|---|---|---|----|---|---|---|---|---|---|---|
| 0  |   |    | 0 | @ | P | ' | p |   |    |   | 0 | @ | P | ' | p |   |
| 1  |   | !  | 1 | A | Q | a | q |   | !  | 1 | A | Q | a | q |   |   |
| 2  |   | "  | 2 | B | R | b | r |   | "  | 2 | B | R | b | r |   |   |
| 3  |   | #  | 3 | C | S | c | s |   | #  | 3 | C | S | c | s |   |   |
| 4  |   | \$ | 4 | D | T | d | t |   | \$ | 4 | D | T | d | t |   |   |
| 5  |   | %  | 5 | E | U | e | u |   | %  | 5 | E | U | e | u |   |   |
| 6  |   | &  | 6 | F | V | f | v |   | &  | 6 | F | V | f | v |   |   |
| 7  |   | '  | 7 | G | W | g | w |   | '  | 7 | G | W | g | w |   |   |
| 8  |   | (  | 8 | H | X | h | x |   | (  | 8 | H | X | h | x |   |   |
| 9  |   | )  | 9 | I | Y | i | y |   | )  | 9 | I | Y | i | y |   |   |
| CS |   | *  | : | J | Z | j | z |   | *  | : | J | Z | j | z |   |   |
| 8  |   | +  | ; | K | [ | k | { |   | +  | ; | K | [ | k | { |   |   |
| C  |   | ,  | < | L | \ | l |   |   | ,  | < | L | \ | l |   |   |   |
| D  |   | -  | = | M | ] | m | } |   | -  | = | M | ] | m | } |   |   |
| E  |   | .  | > | N | ^ | n | ' |   | .  | > | N | ^ | n | ' |   |   |
| F  |   | /  | ? | O | _ | o | ~ |   | /  | ? | O | _ | o | ~ |   |   |

## Epson Italics Character Set-Letter Quality

|   | 0 | 1  | 2 | 3        | 4        | 5        | 6        | 7 | 8  | 9 | A        | B        | C        | D        | E | F |
|---|---|----|---|----------|----------|----------|----------|---|----|---|----------|----------|----------|----------|---|---|
| 0 |   |    | 0 | @        | P        | '        | p        |   |    |   | 0        | @        | P        | '        | p |   |
| 1 |   | !  | 1 | A        | Q        | a        | q        |   | !  | 1 | A        | Q        | a        | q        |   |   |
| 2 |   | "  | 2 | B        | R        | b        | r        |   | "  | 2 | B        | R        | b        | r        |   |   |
| 3 |   | #  | 3 | C        | S        | c        | s        |   | #  | 3 | C        | S        | c        | s        |   |   |
| 4 |   | \$ | 4 | D        | T        | d        | t        |   | \$ | 4 | D        | T        | d        | t        |   |   |
| 5 |   | X  | 5 | E        | U        | e        | u        |   | X  | 5 | E        | U        | e        | u        |   |   |
| 6 |   | &  | 6 | F        | V        | f        | v        |   | &  | 6 | F        | V        | f        | v        |   |   |
| 7 |   | '  | 7 | G        | W        | g        | w        |   | '  | 7 | G        | W        | g        | w        |   |   |
| 8 |   | (  | 8 | H        | X        | h        | x        |   | (  | 8 | H        | X        | h        | x        |   |   |
| 9 |   | )  | 9 | I        | Y        | i        | y        |   | )  | 9 | I        | Y        | i        | y        |   |   |
| A |   | *  | : | J        | Z        | j        | z        |   | *  | : | J        | Z        | j        | z        |   |   |
| B |   | +  | ; | <b>K</b> | <b>I</b> | <b>k</b> | <b>l</b> |   | +  | ; | <b>K</b> | <b>I</b> | <b>k</b> | <b>l</b> |   |   |
| C |   | ↓  | < | <b>L</b> | \        | <b>l</b> | <b>:</b> |   | ↓  | < | <b>L</b> | \        | <b>l</b> | <b>:</b> |   |   |
| D |   | -  | = | <b>M</b> | ]        | <b>m</b> | <b>]</b> |   | -  | = | <b>M</b> | ]        | <b>m</b> | <b>j</b> |   |   |
| E |   | .  | > | N        | ^        | n        | '        |   | .  | > | N        | ^        | n        | '        |   |   |
| F |   | /  | ? | O        | -        | o        | ~        |   | /  | ? | O        | -        | o        | ~        |   |   |

## Epson Graphics Character Set-Draft (Control Codes Disabled)

|   | 0 | 1 | 2  | 3 | 4 | 5 | 6 | 7 | 8 | 9 | A | B | C | D | E | F |
|---|---|---|----|---|---|---|---|---|---|---|---|---|---|---|---|---|
| 0 |   |   |    | 0 | @ | P | ' | p | Ç | É | á |   | L | l | α | # |
| 1 |   |   | !  | 1 | A | Q | a | q | Ü | Æ | í |   | l | l | β | H |
| 2 |   |   | "  | 2 | B | R | b | r | é | ø | ó |   | l | l | Γ | I |
| 3 |   |   | #  | 3 | C | S | c | s | â | ö | ú |   | l | l | Π | V |
| 4 |   |   | \$ | 4 | D | T | d | t | ä | õ | ü |   | l | l | Σ | W |
| 5 |   | § | %  | 5 | E | U | e | u | å | ö | ñ |   | l | l | α | V |
| 6 |   |   | &  | 6 | F | V | f | v | ç | ö | ñ |   | l | l | μ | U |
| 7 |   |   | '  | 7 | G | W | g | w | ç | ö | ñ |   | l | l | π | U |
| 8 |   |   | (  | 8 | H | X | h | x | è | ö | ñ |   | l | l | φ | U |
| 9 |   |   | )  | 9 | I | Y | i | y | è | ö | ñ |   | l | l | θ | U |
| A |   |   | *  | : | J | Z | j | z | è | ö | ñ |   | l | l | θ | U |
| B |   |   | +  | ; | K | [ | k | { | è | ö | ñ |   | l | l | δ | U |
| C |   |   | ,  | < | L | ] | l | } | è | ö | ñ |   | l | l | δ | U |
| D |   |   | -  | = | M | ^ | m | ~ | è | ö | ñ |   | l | l | δ | U |
| E |   |   | .  | > | N | ~ | n | ~ | è | ö | ñ |   | l | l | δ | U |
| F |   |   | /  | ? | O | ~ | o | ~ | è | ö | ñ |   | l | l | δ | U |

## Epson Graphics Character Set-Letter Quality (Control Codes Disabled)

|   | 0 | 1 | 2  | 3 | 4 | 5 | 6 | 7 | 8 | 9 | A | B | C | D | E | F |
|---|---|---|----|---|---|---|---|---|---|---|---|---|---|---|---|---|
| 0 |   |   |    | 0 | @ | P | ' | p | Ç | É | á |   | L | l | α | # |
| 1 |   |   | !  | 1 | A | Q | a | q | Ü | Æ | í |   | l | l | β | H |
| 2 |   |   | "  | 2 | B | R | b | r | é | ø | ó |   | l | l | Γ | I |
| 3 |   |   | #  | 3 | C | S | c | s | â | ö | ú |   | l | l | Π | V |
| 4 |   |   | \$ | 4 | D | T | d | t | ä | õ | ü |   | l | l | Σ | W |
| 5 |   | § | %  | 5 | E | U | e | u | å | ö | ñ |   | l | l | α | V |
| 6 |   |   | &  | 6 | F | V | f | v | ç | ö | ñ |   | l | l | μ | U |
| 7 |   |   | '  | 7 | G | W | g | w | ç | ö | ñ |   | l | l | π | U |
| 8 |   |   | (  | 8 | H | X | h | x | è | ö | ñ |   | l | l | φ | U |
| 9 |   |   | )  | 9 | I | Y | i | y | è | ö | ñ |   | l | l | θ | U |
| A |   |   | *  | : | J | Z | j | z | è | ö | ñ |   | l | l | θ | U |
| B |   |   | +  | ; | K | [ | k | { | è | ö | ñ |   | l | l | δ | U |
| C |   |   | ,  | < | L | ] | l | } | è | ö | ñ |   | l | l | δ | U |
| D |   |   | -  | = | M | ^ | m | ~ | è | ö | ñ |   | l | l | δ | U |
| E |   |   | .  | > | N | ~ | n | ~ | è | ö | ñ |   | l | l | δ | U |
| F |   |   | /  | ? | O | ~ | o | ~ | è | ö | ñ |   | l | l | δ | U |



# Epson Graphics Character Set (Control Codes Enabled)

|   | 0 | 1  | 2 | 3 | 4 | 5 | 6 | 7 | 8 | 9 | A | B | C | D | E | F |
|---|---|----|---|---|---|---|---|---|---|---|---|---|---|---|---|---|
| 0 |   |    |   | 0 | @ | P | ' | p |   |   | á | í | ó | ú | ñ | Ñ |
| 1 |   | !  | 1 | A | Q | R | a | q |   |   | í | ó | ú | ñ | Ñ | á |
| 2 |   | "  | 2 | B | R | S | b | r |   |   | ó | ú | ñ | Ñ | á | í |
| 3 |   | #  | 3 | C | S | T | c | s |   |   | ó | ú | ñ | Ñ | á | í |
| 4 |   | \$ | 4 | D | T | U | d | t |   |   | ó | ú | ñ | Ñ | á | í |
| 5 |   | %  | 5 | E | U | V | e | u |   |   | ó | ú | ñ | Ñ | á | í |
| 6 |   | &  | 6 | F | V | W | f | v |   |   | ó | ú | ñ | Ñ | á | í |
| 7 |   | '  | 7 | G | W | X | g | w |   |   | ó | ú | ñ | Ñ | á | í |
| 8 |   | (  | 8 | H | X | Y | h | x |   |   | ó | ú | ñ | Ñ | á | í |
| 9 |   | )  | 9 | I | Y | Z | i | y |   |   | ó | ú | ñ | Ñ | á | í |
| A |   | *  | : | J | Z | [ | j | z |   |   | ó | ú | ñ | Ñ | á | í |
| B |   | +  | ; | K | [ | \ | k | [ |   |   | ó | ú | ñ | Ñ | á | í |
| C |   | ,  | < | L | \ | ] | l | ] |   |   | ó | ú | ñ | Ñ | á | í |
| D |   | -  | = | M | ] | ^ | m | ^ |   |   | ó | ú | ñ | Ñ | á | í |
| E |   | .  | > | N | ^ | _ | n | _ |   |   | ó | ú | ñ | Ñ | á | í |
| F |   | /  | ? | O | _ | ~ | o | ~ |   |   | ó | ú | ñ | Ñ | á | í |

## Proportional Width Tables

This table lists the widths of the LQ-2500's proportional characters. The values given are in 360ths of an inch (for example: a value of 36 is 36/360ths of an inch). You may need to enter these widths into a special table for your **word** processing program so it can calculate the number of proportional characters that will fit on each line.

The characters with no code indicated are international characters. See Chapter 5 for information on their use. The table shows the character, its ASCH **code** (decimal), and its width.

Table B- 1. Proportional character widths

| Character | Code | Size | Character | Code | Size |
|-----------|------|------|-----------|------|------|
|           | 32   | 30   | 8         | 56   | 30   |
| !         | 33   | 18   | 9         | 57   | 30   |
| "         | 34   | 30   | :         | 58   | 18   |
| #         | 35   | 30   | :         | 59   | 18   |
| \$        | 36   | 30   | <         | 60   | 30   |
| %         | 37   | 36   | =         | 61   | 30   |
| &         | 38   | 36   | >         | 62   | 30   |
| '         | 39   | 18   | ?         | 63   | 30   |
| (         | 40   | 24   | @         | 64   | 36   |
| )         | 41   | 24   | A         | 65   | 36   |
| *         | 42   | 30   | B         | 66   | 36   |
| +         | 43   | 30   | C         | 67   | 36   |
| ,         | 44   | 18   | D         | 68   | 36   |
| -         | 45   | 30   | E         | 69   | 36   |
| .         | 46   | 18   | F         | 70   | 36   |
| /         | 47   | 30   | G         | 71   | 36   |
| 0         | 48   | 30   | H         | 72   | 36   |
| 1         | 49   | 30   | I         | 73   | 24   |
| 2         | 50   | 30   | J         | 74   | 30   |
| 3         | 51   | 30   | K         | 75   | 36   |
| 4         | 52   | 30   | L         | 76   | 36   |
| 5         | 53   | 30   | M         | 77   | 42   |
| 6         | 54   | 30   | N         | 78   | 36   |
| 7         | 55   | 30   | O         | 79   | 36   |

Table B-1. Proportional character widths (continued)

| Character | Code | Size | Character | Code | Size |
|-----------|------|------|-----------|------|------|
| P         | 80   | 36   | x         | 120  | 30   |
| Q         | 81   | 36   | y         | 121  | 36   |
| R         | 82   | 36   | z         | 122  | 30   |
| S         | 83   | 36   | {         | 123  | 24   |
| T         | 84   | 36   |           | 124  | 18   |
| U         | 85   | 42   | }         | 125  | 24   |
| V         | 86   | 36   | ~         | 126  | 30   |
| W         | 87   | 42   | °         |      | 24   |
| X         | 88   | 36   | ¤         |      | 30   |
| Y         | 89   | 36   | β         |      | 36   |
| Z         | 90   | 30   | ø         |      | 36   |
| [         | 91   | 24   | φ         |      | 30   |
| \         | 92   | 30   | °°        |      | 30   |
| ]         | 93   | 24   | §         |      | 30   |
| ^         | 94   | 30   | ü         |      | 36   |
| _         | 95   | 30   | é         |      | 30   |
| ·         | 96   | 18   | ä         |      | 30   |
| a         | 97   | 30   | Å         |      | 30   |
| b         | 98   | 36   | å         |      | 30   |
| c         | 99   | 30   | ç         |      | 30   |
| d         | 100  | 36   | è         |      | 30   |
| e         | 101  | 30   | ì         |      | 18   |
| f         | 102  | 24   | Ä         |      | 36   |
| g         | 103  | 36   | Å         |      | 36   |
| h         | 104  | 36   | É         |      | 36   |
| i         | 105  | 18   | æ         |      | 42   |
| j         | 106  | 24   | Æ         |      | 42   |
| k         | 107  | 36   | ö         |      | 30   |
| l         | 108  | 18   | ó         |      | 30   |
| m         | 109  | 42   | ù         |      | 36   |
| n         | 110  | 36   | Ö         |      | 36   |
| o         | 111  | 30   | Û         |      | 42   |
| p         | 112  | 36   | £         |      | 30   |
| q         | 113  | 36   | ¥         |      | 36   |
| r         | 114  | 30   | Pl        |      | 42   |
| s         | 115  | 30   | ñ         |      | 36   |
| t         | 116  | 24   | Ñ         |      | 36   |
| u         | 117  | 36   | ¿         |      | 30   |
| v         | 118  | 36   | ¡         |      | 30   |
| w         | 119  | 42   |           |      |      |

Table B-1. Proportional character widths (continued)

Super/subscript

| Character | Code | Size |
|-----------|------|------|
|           | 32   | 20   |
| '         | 33   | 12   |
| ''        | 34   | 20   |
| #         | 35   | 20   |
| \$        | 36   | 20   |
| %         | 37   | 24   |
| &         | 38   | 24   |
| .         | 39   | 12   |
| (         | 40   | 16   |
| )         | 41   | 16   |
| *         | 42   | 20   |
| -         | 43   | 20   |
|           | 44   | 12   |
| _         | 45   | 20   |
|           | 46   | 12   |
| /         | 47   | 20   |
| 0         | 48   | 20   |
| 1         | 49   | 20   |
| 2         | 50   | 20   |
| 3         | 51   | 20   |
| 4         | 52   | 20   |
| 5         | 53   | 20   |
| 6         | 54   | 20   |
| 7         | 55   | 20   |
| 8         | 56   | 20   |
| 9         | 57   | 20   |
|           | 58   | 12   |
|           | 59   | 12   |
| <         | 60   | 20   |
| =         | 61   | 20   |
| >         | 62   | 20   |
| ?         | 63   | 20   |
| @         | 64   | 24   |
| A         | 65   | 24   |
| B         | 66   | 24   |
| C         | 67   | 24   |
| D         | 68   | 24   |
| E         | 69   | 24   |

| Character | Code | Size |
|-----------|------|------|
| F         | 70   | 24   |
| G         | 71   | 24   |
| H         | 72   | 24   |
| I         | 73   | 16   |
| J         | 74   | 20   |
| K         | 75   | 24   |
| L         | 76   | 24   |
| M         | 77   | 28   |
| N         | 78   | 24   |
| O         | 79   | 24   |
| P         | 80   | 24   |
| Q         | 81   | 24   |
| R         | 82   | 24   |
| S         | 83   | 24   |
| T         | 84   | 24   |
| U         | 85   | 28   |
| V         | 86   | 24   |
| W         | 87   | 28   |
| X         | 88   | 24   |
| Y         | 89   | 24   |
| Z         | 90   | 20   |
| [         | 91   | 16   |
| \         | 92   | 20   |
| ]         | 93   | 16   |
| ^         | 94   | 20   |
| _         | 95   | 20   |
| `         | 96   | 12   |
| a         | 97   | 20   |
| b         | 98   | 24   |
| c         | 99   | 20   |
| d         | 100  | 24   |
| e         | 101  | 20   |
| f         | 102  | 16   |
| g         | 103  | 20   |
| h         | 104  | 24   |
| i         | 105  | 12   |
| j         | 106  | 16   |
| k         | 107  | 24   |

Table B-1 Proportional character widths (continued)

| Character | Code | Size |
|-----------|------|------|
| l         | 108  | 12   |
| m         | 109  | 28   |
| n         | 110  | 24   |
| o         | 111  | 20   |
| p         | 112  | 24   |
| q         | 113  | 24   |
| r         | 114  | 20   |
| s         | 115  | 20   |
| t         | 116  | 16   |
| u         | 117  | 24   |
| v         | 118  | 24   |
| w         | 119  | 28   |
| x         | 120  | 20   |
| y         | 121  | 24   |
| z         | 122  | 20   |
| {         | 123  | 16   |
|           | 124  | 12   |
| }         | 125  | 16   |
| ~         | 126  | 20   |
| °         | 3    | 16   |
| □         |      | 20   |
| β         |      | 24   |
| o         |      | 24   |
| o         |      | 20   |
| oo        |      | 20   |
| §         |      | 20   |

| Character | Code | Size |
|-----------|------|------|
| u         |      | 24   |
| é         |      | 20   |
| a         |      | 20   |
| á         |      | 20   |
| â         |      | 20   |
| ç         |      | 20   |
| e         |      | 20   |
| i         |      | 12   |
| À         |      | 24   |
| Á         |      | 24   |
| È         |      | 24   |
| É         |      | 28   |
| Ê         |      | 28   |
| Ë         |      | 20   |
| Ö         |      | 20   |
| Ü         |      | 24   |
| Ó         |      | 24   |
| Û         |      | 28   |
| È         |      | 20   |
| ¥         |      | 24   |
| Pl        |      | 28   |
| À         |      | 24   |
| Ñ         |      | 24   |
| ¿         |      | 20   |
| ¡         |      | 12   |

## Typestyle Summary

The LQ-2500 can produce a wide range of typestyles by combining different fonts, character widths, print qualities, and other enhancements. In addition, you can include superscripts and subscripts and underlining with any style you choose. (For more information on selecting different typestyles, see Chapters 2 and 5.)

You have the choice of five different fonts, all of which can be printed in Letter Quality or draft quality. You also have the choice of 10, 12, or 15 pitch or proportional print. Certain pitches are designated for certain fonts. Although you may choose to print a font in other than the designated pitch, it is not recommended. The five fonts you can choose from are:

Table C-1. Available Letter Quality fonts

| Font name  | Designated pitch | Proportional |
|------------|------------------|--------------|
| Roman      | 10, 15           | yes          |
| Sans Serif | 10, 15           | yes          |
| Courier    | 10, 15           | no           |
| Prestige   | 12               | no           |
| Script     | 10, 15           | no           |

The following samples show you the character set available for each font. Below each set is an example of how the font looks **when** combined with certain enhancements such as underlining or emphasized type. As you can see, different fonts lend themselves to different applications.

### Roman

!"#\$%&'()\*+,-./0123456789:;<=>?@ABCDEFGHIJK  
LMNOPQRSTUVWXYZ[\]^\_`'abcdefghijklmnopqrstuv  
wxyz{|}~à°çšéùè"ÀÖäöüß££ØAæø&ñÉéüR;N¿ñŸ

We've just seen your excellent ad for  
miniature zebras in a recent back issue  
of Trader's Times. What is the price  
schedule for quantities over one gross?

---

**San Serif**

!"#\$%&'()\*+,-./0123456789:;<=>?@ABCDEFGHIJK  
LMNOPQRSTUVWXYZ[\]^\_`abcdefghijklmnopqrstuv  
wxyz{|}~à°ç§éùè"ÀÖäöüßƒÆΘΑæøâœÉÉÛΠ;Ñ;ñ¥

We've just seen your excellent ad for miniature zebras in a recent back issue of Trader's Times. What is the price schedule for quantities over one gross?

**Courier**

!"#\$%a'()\*+,-./0123456789:;<=>?@ABCDEFGHIJK  
LMNOPQRSTUVWXYZ[\\]--`abcdefghijklmnopqrstuv  
wxyz{|}~à°ç§éùè"ÀÖäöüßƒÆΘΑæøâœÉÉÛΠ;Ñ;ñ¥

We've just seen your excellent ad for **miniature zebras** in a recent back issue of Trader's Times. What is the price schedule for quantities over one *gross*?

**Prestige**

!"#\$%a'()\*+,-./0123456789:;<=>?@ABCDEFGHIJK  
LMNOPQRSTUVWXYZ[\\]--`abcdefghijklmnopqrstuv  
wxyz{|}~à°ç§éùè"ÀÖäöüßƒÆΘΑæøâœÉÉÛΠ;Ñ;ñ¥

We've just seen your **excellent** ad for **miniature zebras** in a recent back issue of Trader's Times. What is the price schedule for quantities over one gross?

**script**

!"#\$%&'()\*+,-./01234567%9:;<=>?@ABCDEFGHIJK  
LMNOPQUSTUUVWXYZ[\~^\_`'a b c d e & M j ' h & n n o p q l u  
wxyz{|}~à°ç§éùè"ÀÖäöüßƒÆΘΑæøâœÉÉÛΠ;Ñ;ñ¥

We've just seen your excellent and for miniature zebras in a recent back issue of traders's Times. What is the price schedule for quantities over on gross?

---

## Epson Draft

You can also print in Epson draft quality for high-speed printing. Although there are five Letter Quality fonts, when you select draft you will always print in the style shown below.

!"#\$%&'()\*+,-./0123456789:;<=>??@ABCDEFGHIJK  
LMNOPQRSTUVWXYZ[\]^\_`'abcdefghijklmnopqrstuv  
wxyz{|}~`ª°ç§èùë"Àáâöüß£ÆØÅæøåðÉëÛŔ;ıŃłñŸ

We've Just seen your excellent ad for  
miniature zebras In a recent back issue  
of Trader '5. Times. What is the price  
schedule for quantities over one gross'?

---

## Selecting Typestyles with Master Select

The LQ has a special ESCape code called Master Select that allows you to choose many possible combinations of nine different modes: 10 pitch, 12 pitch, proportional, condensed, emphasized, doublestrike, double-width, italic, and underline. The format of the Master Select code is shown below:

---

|              |            |          |          |
|--------------|------------|----------|----------|
| ASCII:       | <b>ESC</b> | <b>!</b> | <b>n</b> |
| Decimal:     | 27         | 33       | n        |
| Hexadecimal: | 1B         | 2 1      | n        |

---

The variable *n* is a number that identifies the typestyle or combination. To find the value of *n*, refer to Table C-2 and add up either the decimal or hexadecimal numbers for the features you want.



Table C-2. Master Select

| Feature       | Dec. | Hex. | SelectType |
|---------------|------|------|------------|
| 10 pitch      | 0    | 00   | Yes        |
| 12 pitch      | 1    | 01   | Yes        |
| proportional  | 2    | 02   | Yes        |
| condensed     | 4    | 04   | Yes        |
| emphasized    | 8    | 08   | No         |
| double-strike | 16   | 10   | No         |
| double-width  | 32   | 20   | No         |
| italic        | 64   | 40   | No         |
| underline     | 128  | 80   | No         |

For example, to print a title, you may want to use double-width 10 pitch characters and print them in double-strike mode. You would add three numbers together to calculate the value of  $n$ .

10 pitch                    0  
Double-strike 16  
Double-width 32  
 $n = 48$

After calculating the value of  $n$ , you would use the Master Select command to send the value to the printer.

---

|              |     |     |     |
|--------------|-----|-----|-----|
| ASCII:       | ESC |     |     |
| decimal:     | 27  | 313 | 408 |
| hexadecimal: | 1B  | 21  | 30  |

---

The print quality and font must be set separately either using SelectType or the ESC x and ESC k commands. There are two more things to take into account when using the Master Select command:

1. Master Select cancels any of the listed features that you do not try to set. For example, if you have already set a different character width, and you try to use Master Select to set emphasized double-strike, the character width is reset to 10 pitch.
2. Proportional overrides 10, 12, and 15 pitch.

## Problem Solving and Maintenance

This appendix presents solutions for possible problems, explanations of the LQ's advanced features, and tips on maintaining and transporting your printer.

### General Troubleshooting

| Problem                | Recommendation  |
|------------------------|---|
| Printer does not print | <p>Make sure that the printer is turned on, and that the POWER light is on.</p> <p>Make sure that the printer is on line-the ON LINE light should be on, and the display should show [ON LINE].</p> <p>Make sure that the printer and computer are connected. Be certain you are using the correct cable.</p> <p>Make sure the printer is only connected to one interface and that you have selected that interface with SelecType (see Chapter 2).</p> <p>If the program you are using allows you to choose between screen output and printer output, make sure that you have selected printer output.</p> <p>If the printer still does not print, try the self test procedure (see Chapter 1). If the self test works correctly the printer is all right, and the problem lies elsewhere. If the self test doesn't work, contact your dealer.</p> |

| <b>Problem</b>                                     | <b>Recommendation</b>   |
|--|---|
| Printing is patchy, faint, uneven, or intermittent | <p>Check that the ribbon is seated correctly and that the pins at either side are located properly in the holes in the ribbon carriage.</p> <p>If you have removed the color option kit, consult the user's guide to check that the ribbon carriage is set correctly.</p> <p>Check that the ribbon moves freely in the cartridge.</p> <p>If you have been using the ribbon for a long time or for a large amount of printing, it may need replacing.</p> <p>It is also possible for the print head to wear out if the printer is used frequently and for long periods at a time.</p> <p>Contact your dealer for a replacement print head. Never attempt to replace It yourself because other parts of the printer should be checked at the same time.</p> |
| Alternate lines are printed backwards              | This may happen If you have been using a word processing program set up for a daisywheel printer. and then switch to a dot matrix printer such as the LQ. Consult your application program manual for informatron on how to adjust the program.   |
| All the text is printed on the same line           | This happens if no line feed signal is being sent at the end of each line of text. Check the AUTO LINE FEED setting under SelecType's DEFAULT SEIIT-Gs.   |
| Text is printed with an extra blank line between   | Two line feed signals are being sent. Check the AUTO LINE FEED setting under SelecType's DEFAULT SETTINGS.  |

| <b>Problem</b>  | <b>Recommendation</b>  |
|---|--|
| Some of the characters printed do not match those in the file | Check the SelecType Country setting in Chapter 2, and see the International Character Tables in Appendix B.  |
| Paper feeding problems  | See Chapter 3 for specific instructions on loading paper.  |
| Regular gaps appear in pnnntouts                              | Check the SelecType settings to ensure that you've selected the correct paper size.  |
| Self test pattern is garbled                                  | If the test pattern did not print as shown in Step 8 of Chapter 1, the printer is faulty. Refer the problem to your dealer. If the pattern is printed but is patchy or faint, check that the ribbon is installed correctly.  |
| Beeper sounds and printer stops                               | The paper sensor is not covered properly. Turn the printer off and check to see that the paper is loaded correctly   |
| Beeper sounds six times and printer stops                     | If the printer beeps six times (in two groups of three), there is a problem with the print head and ribbon carriage. Turn off the printer and refer the problem to your dealer.  |
| PRINT HEAD HOT WAIT!  | <p>Check the SelecType panel lights. If [PRINT HEAD HOT WAIT! is displayed, the print head is becoming too hot and the printer has stopped to protect it from damage.</p> <p>When the print head cools down, the printer beeps once more, the ON LINE and READY lights come ON again, the panel displays t ON LINEI, and printing resumes. You do not have to do anything to restart the printing. Don't worry if the print head gets hot. it is only likely to happen during long periods of graphics printing.</p> |

---

---

## Troubleshooting Graphics Problems

| Problem   | Recommendation  |
|---|---|
| Strange dot patterns appear in graphics printouts   | <p>Many computers have problems sending one or more of the codes between 0 and 13. Try to avoid these characters if possible.</p> <p>Be sure that no other commands or carriage returns come between the graphics command and its data.</p>   |
| Printer freezes when printing graphics  | <p>If the printer freezes in graphics mode, you have sent too few columns of data. Be aware that in 24-pin graphics mode three data bytes per column of graphics are required.</p>  |
| Text appears as random graphics characters  | <p>If you interrupt the computer while it is printing in graphics mode, for example during a screen dump, it may not reset the printer to text mode. If not, the next text printed will be interpreted by the printer as graphics data. Turn off the printer and turn it back on again to reset it.</p>   |
| You don't see the graphics characters you expect or italics are printed instead of graphics | <p>Select the LQ-2500 printer from the printer driver list in your application program. Make sure you select the Graphic option from the SelectType CG TABLE. If your application program does not list the LQ-2500. or the LQ-80011000 with the ESCIP module, check with your dealer to find out whether you can obtain an upgrade for the software that supports the LQ-2500.</p> |

---

---

## Troubleshooting for Serial Interface Communications

| Problem                                     | Recommendation   |
|---|--|
| Printer prints one character then stops     | The LQ uses the DTR signal and the X-on/X-off protocol (via TXD) to tell the computer whether it is ready to receive characters or whether it is busy printing. Refer to your computer's documentation and ensure that the computer is using one of these systems. You may also need to check your cable wiring or ask your dealer to do it for you. |
| READY light flickers but nothing is printed | Data is getting through to the printer but is not being interpreted correctly. Make sure that both the printer and computer are using the same baud rate, number of start and stop bits, and the same parity.  |
| All printing is garbled                     | Make sure that both the computer and printer are set to use the same number of data bits per word (8) and that they both use the same parity, baud rates, and number of start and stop bits.   |

---

## Hex Dump Mode

The LQ has a special feature that makes it easy for experienced printer users to find the causes of problems. The hexadecimal (hex) or data dump mode gives a printout of exactly what codes reach the printer.

Enter this mode by turning on the printer while holding down the **FORM FEED** and **LINE FEED** buttons at the same time. Then, when you run a program, either an application program or one you have written in any programming language, the LQ prints, in the hex format, all the codes being sent to the printer.

The data dump below was made while writing this appendix. By comparing the guide section on the right with the printout of hex codes,

you can see what codes are being sent to the printer. If characters are printable, they appear as their true ASCII characters. Non-printable codes, such as control codes are shown by a dot.

```

16 38 12 1B 50 1B 32 0A OD 0A 00 0A OD 0A OD OD .8..P.2.....
41 70 70 65 6E 64 69 78 20 44 20 70 72 65 73 65 Appendix D prese
6E 74 73 20 73 6F 6C 75 74 69 6F 6E 73 20 66 6F nts solutions fo
72 20 70 6F 73 73 69 62 6C 65 20 70 72 6F 62 6C r possible probl

```

Find the hex code, 41, at the beginning of the second line. Then find the character, A, at the beginning of the second line in the guide section. The hex code for A is 4 1.

To interpret the non-printable codes, use the ASCII Conversion Chart on the Quick Reference card to find the meaning of the hex code and then look at the Command Summary to find what the control code tells the printer to do.

In the hex dump above, the first hex code, 1B, represented by a dot, is the ESC code. It is followed by hex 38, which is printed as 8. Together, these two codes combine to become ESC 8 which is the control code that tells the printer to ignore the paper-out sensor

The chart below interprets the first six codes for you.

| <b>Hex codes</b> | <b>Command</b> | <b>Function</b>              |
|------------------|----------------|------------------------------|
| 1B 38            | ESC8           | Disable paperout sensor      |
| 12               | DC2            | Cancel condensed mode        |
| 1B50             | ESC P          | Select pica pitch            |
| 1B 32            | ESC2           | Select 1 G-inch line spacing |
| 0A               |                | Line Feed                    |
| OD               | &              | Carriage Return              |

If you find codes in your hex dump that you did not enter in your program or codes you did not expect your application program to send, your computer may be changing the codes before sending them to the printer. You will need to adjust the program.

Hex dump mode can be turned off by turning off the printer: it is also cancelled by an INIT signal from the computer.

---

## **Solutions for IBM and Compatibles**

If you suspect that your computer or software is causing a problem, consult your users manuals for those products. Some problems may arise when using operating system commands or writing your own programs in the computer's resident language. Some general advice for IBM PC and compatible users is offered in this section.

---

### **IBM PC BASIC Solutions**

IBM PC BASIC inserts a carriage return and line feed (CR-LF) after each 80 characters you send it. It also adds a line feed to each carriage return included explicitly in an LPRINT statement. Use the BASIC statement WIDTH LPRINT 255 to remove this problem. The 255 is a special number that prevents the computer system from inserting a CR-LF into the line unless there is one in your program.

The extra line feed character is usually no problem, unless you want to send ASCII code 13 on its own as part of a graphics statement or a character definition. To do this, use the OPEN statement to assign a file number to the printer (LPT1:) and use the PRINT# statement in place of LPRINT. You also need to use a slightly different WIDTH statement. To prepare the printer in this way use a line like this:

```
100 OPEN "LPT1: AS 81 : WIDTH #1, 255
```

A third problem exists with IBM PC BASIC release 2.0. This version cannot send ASCII code 26 (1A hex) either with LPRINT or with PRINT #. Try to avoid including this code in your programs.

---

### **Maintaining Your Printer**

Always keep the printer in a clean and safe place. Keep it away from dust, grease, moisture and any source of heat, including direct sunlight. A safe temperature range is 5°C to 35°C (40°F to 95°F).

If the outer case is dirty clean it with a soft, clean cloth dampened with mild detergent dissolved in water. Keep the dust cover in place to prevent any water from getting inside the printer. Do not use a hard



---

brush or cloth, and never use alcohol or a thinner to clean the printer, because it could damage the print head and the case.

Do not spray the inside of the printer with oil: unsuitable oils can damage the mechanism. If lubrication is needed, contact your Epson dealer.

### **The print head**

Be particularly careful with the print head. Never move it when the printer is turned on. When the printer is printing, the print head becomes hot. If you need to change the ribbon or load continuous paper, turn the printer off and wait for a few minutes while the print head cools down.

The print head should last for about 200 million strokes per wire. When it fails, one or more of the pins may fire erratically or stop firing completely, making the printout patchy. If this happens suddenly or long before the expected lifetime is over, the problem is almost certainly connected with another component of the printer.

As soon as the print head fails, stop using the printer and contact your Epson dealer for a replacement head. Do not attempt to replace the head yourself, because the printer should also be tested to make sure that no other parts are damaged.

---

### **Transporting the Printer**

There are several precautions you should take when packing the printer for transportation:

- Remove the ribbon.
- Insert a piece of paper to cover the paper-out sensor.
- Move the print head to the left and replace the print head protector.
- Remove the paper rest and paper guide and pack them separately.
- Fix the dust cover in place with tape.
- Remove the paper feed knob.
- Pack the printer in the original foam packing supports and box.

### Initialization and Default Settings

There are three ways that the printer can be initialized (returned to a fixed set of conditions).

1. The power is turned **ON**.
2. The printer receives an m signal at the parallel interface (pin 31 becomes LOW).
3. Software sends the ESC @ command.

These three kinds of initialization have slightly different effects. In particular, ESC @ resets the typestyle to the current SelecType settings; the other two methods reset the typestyle according to the SelecType Default Settings. These Default Settings are set only by hardware initialization and are not set by ESC @. Also, ESC @ does not initialize the printer mechanism, clear-the input data buffer, or clear the Download character set.

The following conditions are always reset:

- Present paper position becomes top of page position.
- The left margin is set to the SelecType Default Settings.
- The line spacing is set to 1/64nch.
- The vertical tab position is cleared.
- The horizontal tab position is set to every eight characters.
- The VFU channel becomes channel 0.
- The family of typestyle is set to the Selectype Default Settings.
- All special printing effects are cancelled unless they are part of the SelecType Default Settings.
- Download characters are cleared (with software initialization, they are only deselected).
- Justification becomes left justification.
- No additional character spacing is provided.

- 
- The bit image mode assignment is:  
ESCK=ESC\*0,ESCL=ESC\*1,ESCY=ESC\*2,  
ESCz=Esc\*3.

In addition, when the printer is initialized by turning on the power or by an INIT signal, the data buffer is cleared of all text.

# Choosing and Setting Up Optional Interfaces

This appendix contains information on Epson interfaces compatible with LQ printers, instructions on choosing the right interface for a particular job, and instructions for installing internally mounted interface boards.

---

## Compatible Interfaces

You can use a number of optional interfaces that supplement the LQ's built-in parallel and serial interfaces and the standard 8K data buffer. These fall into three main categories:

- IEEE-488 and other special interfaces, which allow connection to computers with other interface requirements (the Apple interface is installed in the computer rather than the printer)
- Buffer interfaces, which provide a larger data buffer to release the computer for other tasks when printing large amounts of text
- Serial interfaces providing additional features not available with the standard interface.

The following Epson interfaces are compatible with LQ printers. Note that some of these are no longer available, and that others are not available in all countries.

|        |   |
|--------|---|
| *8131  | Apple II parallel interface                                       |
| *8143  | Serial interface with baud rate selectable between<br>75 and 9600 |
| *8145  | RS-232Wcurrent loop interface type 2                              |
| #8148  | Intelligent serial interface                                      |
| “8149  | 32K buffer serial interface                                       |
| %149M  | 128K buffer serial interface                                      |
| *8161  | IEEE-188 interface  |
| *8165  | Intelligent IEEE-488 interface                                    |
| *8172  | 32K buffer parallel interface                                     |
| *8172M | 128K buffer parallel interface                                    |

If you are using an optional internal interface, select parallel on your SelecType panel and do not connect anything to the parallel interface connector in the rear of the printer.

---

## Choosing an Interface

This section describes the interfaces.

### IEEE-488 and Apple interfaces

The IEEE-488 system allows you to connect computers, printers, and other peripherals so that they can share data freely. Epson offers two types of IEEE488 interfaces. The #8161 offers the basic ability to operate in the IEEE-488 address and listen-only modes. The \*8165 has the basic features and an 8K data buffer and a line monitor function, which provides a diagnostic printout of IEEE488 commands.

The Apple II, II + and He computers do not have a printer interface as a standard feature. Epson produces a parallel interface board for the Apple, which has software to control the functions of the printer. With the \*8131 interface installed in the Apple, no additional interface is needed in the printer. An Apple IIC requires only a suitable cable for use with the LQ.

### Buffered interfaces

If you often print very large amounts of text, a buffered interface can free the computer for other tasks. Serial and parallel buffered interfaces are available to increase the printer's data buffering capacity to either 32K or 128K (about 20 and 80 pages). See Table F-1.

*Table F 1. Buffered Interfaces*

|              | Serial        | Parallel      |
|--------------|---------------|---------------|
| <b>32K:</b>  | <b>#8149</b>  | <b>#8172</b>  |
| <b>128K.</b> | <b>#8149M</b> | <b>#8172M</b> |

### Serial interfaces

The built-in serial interface on LQ printers is suitable for almost all applications. If, however, you need an interface that allows different serial settings or that conforms to the Current Loop standard rather than Rs232C, you can install an optional interface.

Three Epson serial interfaces are suitable for LQ printers. All three offer a choice of 7-bit or g-bit data, and support Current Loop operation in addition to RS-232C. They also offer a choice of other features, which are listed in Table F-2.

*Table F-2. Send interface*

|                      | #a143 | #a145    | #a148                     |
|----------------------|-------|----------|---------------------------|
| X-on/X-off control   | yes   | no       | yes                       |
| Self test            | no    | loopback | loopback/<br>line monitor |
| Built-In data buffer | none  | 2K       | 218K                      |

X-on/X-off protocol is a system in which the printer transmits a code to the computer to indicate that it cannot accept more data, and a second code when it is once more ready

The loopback self-test mode allows direct testing of the functions of the interface without connecting a computer; line monitor mode is rather like the LQ data dump mode.

### **Identifying a serial interface board**

All Epson interfaces have the EPSON name printed on them. If the board has an identification code printed on it, it will be a four digit number beginning with an eight. The number should be one of the numbers in Table F-3.

If the board has no identification code, or if you are unsure whether the number you have located is the correct code, check the number of DIP switches on the board against Table F-3.

*Table F-3. Number of DIP switches*

| Interface number | DIP switch group |      |
|------------------|------------------|------|
|                  | 1                | 2    |
| #8143            | 8                | none |
| #8145            | 8                | 4    |
| #8148            | 8                | 6    |
| #8149(M)         | 8                | 8    |

---

---

## Installing an Interface

Before installing an interface, you must remove the printer's cover,

---

### WARNING

Do not remove the cover unless the printer is turned OFF because high voltages are present inside the printer when the power is on. Also do not touch contacts on the circuit board of the printer because many of the components can be destroyed by the static electricity charge that may build up on your **body**

---

1. Turn off the power to both the printer and the computer and unplug the power cable and disconnect the interface cable from the printer.
2. Remove the dust cover and paper guide.
3. Remove the automatic sheet feeder if one is installed.
4. Remove the option compartment cover and any optional cartridges you have installed.
5. Remove the ribbon and move the print head to the middle of the printer.
6. Remove the screws holding the upper case of the printer (shown in Figure F-1), using a cross-head type screwdriver,

---

**Figure F-1.**  
*Removing the screws*

---

**Figure F-2.**  
*U-lifting the control panel*

- 
7. With the printer facing you, unclip the left side of the control panel and lift it up slightly to release it from the case (Figure F-2).
  8. At each side of the front panel there is a retaining clip, as shown in Figure F-3. One is reached through the control panel opening. Reach behind the cable and gently press the two clips to release the front edge of the upper case.
  9. Tilt the upper case up and slip the control panel through the opening as shown in Figure F-4, being careful not to strain the connector linked to the control panel.
  10. Lift the upper case to release the hinges at the rear edge, then lift it away from the printer

To replace the cover, reverse steps 2 to 10.

---

Figure F-3.  
*Location of retaining clips*

*figure F4.*  
*Removing the case*



---

## Inserting the Interface Board

1. Remove the upper case of the printer, following the steps described in the previous section.
2. Remove the blanking plate above the parallel connector (as shown in Figure F-5) to allow access to the new interface connector when the case is reassembled.
3. Locate the three supports on which the interface board will rest, and the screw at the rear of the circuit board labelled FG. These are also shown in Figure F-5. The screw marked FG is the connection for the frame ground wire. Connect the frame ground wire before inserting the interface.
4. Insert the interface board beneath the printer mechanism, as indicated by the lines in Figure F-6, and plug it into the connector marked CN2 on the main circuit board of the printer.
5. Secure the board to the three supports using the screws provided.
6. Connect the frame ground wire to the ground terminal on the parallel connector, as shown in Figure F-7.
7. Reassemble the printer, reversing the procedure described in the previous section.

---

*Figure F-5.*  
*FG screw and blanking plate*

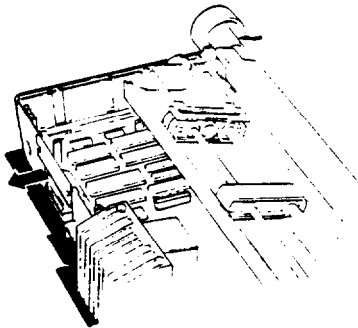

*Figure F-6.*  
*Inserting the board*

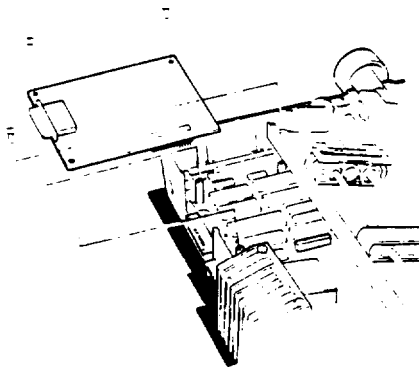

---

## Serial Interface Settings

If you are using an optional serial interface, you may need to change the communications protocol of the printer or the computer for them to communicate properly. The protocol used by the printer is decided by one or two groups of DIP switches located on the serial interface board (not by SelecType settings); the protocol used by the computer can probably be altered by a software command. It is essential that the printer and computer use compatible protocols.

If you can, change the settings on the computer rather than the interface board because the interface is set up at the factory to give optimum performance in a wide range of conditions. If your dealer has installed the interface for you, he or she should also be able to adjust the computer and interface to achieve a good match.

If you do need to change the settings on the interface yourself, (perhaps in order to **use** a different computer), the tables below will help you match the computer and interface. The settings given in the table cover the conventions used by the computer and printer as data is transferred. There are other DIP switches and jumpers, **but** for most purposes you only need change the settings described here. The other settings are described in the manual supplied with the interface.

---

### Note]

The interface board DIP switch settings **override** SelecType settings.

---

*Figure F-1:  
Connecting frame ground wire*

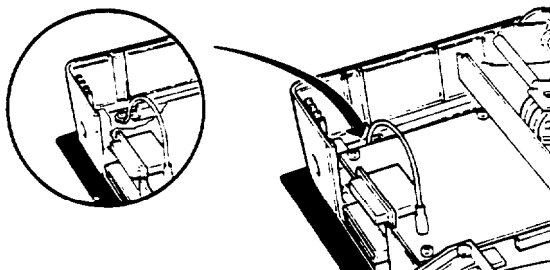

The three following tables contain all the information you need for the optional interface settings.

Table F-4 Baud rate setting

| Interface number | Switches used   |     |     |     |
|------------------|-----------------|-----|-----|-----|
| #8143            | 1-7             | 1-1 | 1-4 | 1-3 |
| #8148            | 1-5             | 1-6 | 1-7 | 1-8 |
| #8149(M)         | 2-5             | 2-6 | 2-7 | 2-8 |
| Baud rate        | Switch settings |     |     |     |
| 300              |                 | OFF |     | OFF |
| 600              | %               | OFF | ON  | ON  |
| 1200             |                 | OFF | OFF | OFF |
| 2400             | ON              | ON  | ON  | OFF |
| 4800             | OFF             |     | OFF |     |
| 9600             | OFF             | ON  | OFF | OFF |

Table FS. Baud rate setting for 8145

| Baud rate | Switch 1-1 | Switch 1-2 | Switch 1-3 | Switch 1-4 |
|-----------|------------|------------|------------|------------|
| 300       | ON         | OFF        | ON         | OFF        |
| 600       |            | OFF        | OFF        |            |
| 1200      | ON         | OFF        | OFF        | ON         |
| 2400      | OFF        | ON         |            | OFF        |
| 4800      | OFF        |            | ON         |            |
| 9600      | OFF        | %          | OFF        | OFF        |

Table F-6. Other settings

| Function           | Number of data bits | Parity check | Parity check | Even/odd parity |
|--------------------|---------------------|--------------|--------------|-----------------|
| switch ON          | 7 bits              | enabled      | dsaaled      | even            |
| switch OFF         | 8 bits              | dsabled      | enaWed       | odd             |
| 1 interface number | Switches used       |              |              |                 |
| #8143              | 1-2                 | 1-6          | 1-7          | 1-8             |
| #8145              |                     |              |              |                 |
| #8148              | 1-1                 | 1-2          |              | 1-3             |
| #8149(M)           | 2-1                 | 2-2          |              | 2-3             |

---

## Technical Specifications

---

### Printing

Printing method

Impact dot matrix

Printing speed

324 characters per second per line in draft 12 pitch

270 characters per second per line in draft 10 pitch

108 characters per second per line in Letter Quality 12 pitch

90 characters per second per line in Letter Quality 10 pitch

Paper feed speed

Approximately 100 ms/line at 1 /&inch line spacing and 2.2 inches per second during continuous feed

Printing direction

Bidirectional logic-seeking for both text and graphic printing

Unidirectional available through SeIecType

Line spacing

1/8-inch, or programmable in increments of 1/180th of an inch

Buffer

Sk

Fonts

Epson Draft

Epson Roman

Epson Sans Serif

Epson Courier

Epson Prestige

Epson Script

Character **tables**

Epson Character Graphic

Epson Italic

International

---

## Paper

### Number of copies

Up to 4 sheets, including the original. Total thickness not to exceed 0.22mm

### Paper width

|                 |                |                  |
|-----------------|----------------|------------------|
| Continuous-feed | 4" to 16"      | (101mm to 406mm) |
| Single-sheet    | 7.15" to 14.3" | (182mm to 364mm) |

---

## Mechanical

### Ribbon

Cartridge, exclusive to LQ-2500, black or color

Life expectancy (in characters, at 48 dots/character) :

Black only: 2 million

Color:

|         |            |
|---------|------------|
| Black:  | 1 million  |
| Red:    | 7 million  |
| Blue:   | .7 million |
| Yellow: | .5 million |

### MCBF

5 million lines (excluding the print head)

### Print head life

200 million strokes per wire

### Dimensions and Weight (excluding knobs and paper guides)

Height: 5.61" (142.5 mm)

Width: 23.25" (591 mm)

Depth: 14.75" (375 mm)

Weight: 26.4 lbs (12 kg)

---

## Electrical

### Voltage

120V AC, f 10%  
Non-switchable

### Consumption

120 VA

### Frequency

49.5 Hz - 60.5 Hz

### Insulation resistance

10 Mohms between AC power line and chassis

### Dielectric strength

120 V model can withstand 1 kV rms applied between AC line and chassis for 1 minute, or 1.25 kV rms for 1 second

---

## Environment

### Temperature

Operation: 40° F to 95° F (5 C to 35 C)  
Storage: -30° F to 150° F (-30 C to 65 C)

### Humidity

Operation: 10% to 80% without condensation  
Storage: 5% to 85% without condensation

### Shock

Operation: Up to 1 G within 1ms  
Storage: Up to 2 G within 1ms

### Vibration

Operation: Up to 0.1 G at up to 55Hz  
Storage: Up to 0.5 G at up to 55Hz

Interfaces (see Appendix H)

## Interface Specifications

The LQ-2500 is equipped with both a parallel and a serial interface. Both are described in this appendix.

### WARNING

Do not connect cables to both interfaces. This may damage your printer.

### The Parallel Interface

This interface offers:

- Connection using a standard 36-pin AMPHENOL 57-30360 connector
- Synchronization of data transfer by external  $\overline{\text{STROBE}}$  pulses
- Handshaking using  $\overline{\text{ACKNLG}}$  and  $\text{BUSY}$  signals
- A full complement of control connections
- TTL-compatible signal levels on all connections for data and control
- Paper-out detection through the  $\text{BUSY PE}$  and  $\overline{\text{ERROR}}$  signals, with the  $\text{BUSY}$  and  $\overline{\text{ERROR}}$  warnings under software control.

Table H-1 shows the purpose of each connection. The figure below shows timing.

Figure H-1.  
Parallel interface timing diagram

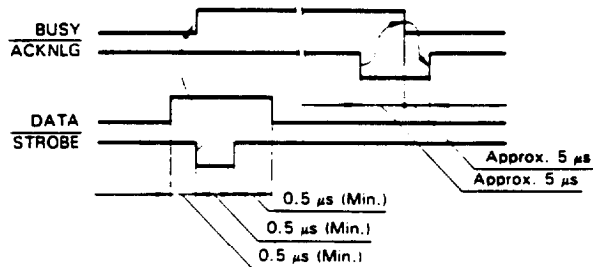

Table H-1. Pins and signals

| signal | return | signal         | direction | description   |
|--------|--------|----------------|-----------|---|
| 1      | 19     | STROBE         | in        | Pulses on this line cause data to be read in.                                   |
| 2      | 20     | DATA 1         | in        | These signals represent data sent to the printer.                               |
| 3      | 21     | DATA 2         | in        |   |
| 4      | 22     | DATA 3         | in        | A HIGH level represents a binary 1 digit.                                       |
| 5      | 23     | DATA 4         | in        |   |
| 6      | 24     | DATA 5         | in        |   |
| 7      | 25     | DATA 6         | in        |   |
| 8      | 26     | DATA 7         | in        |   |
| 9      | 27     | DATA 8         | in        |   |
| 10     | 28     | ACKNLG         | out       | Pulse to show printer is ready for more data.                                   |
| 11     | 29     | BUSY           | out       | Signal set HIGH to show printer cannot accept data.                             |
| 12     | 30     | PE             | out       | Signal set HIGH to show printer is out of paper.                                |
| 13     | —      | SLCT           | out       | Always "HIGH" output. (Pulled up to + 5V through 3.3 kOhms register.)           |
| 14     | —      | AUTO FEED XT   | in        | If this is LOW, a line feed is added to each carriage return.                   |
| 15     | —      | NC             | —         | Not used.   |
| 16     | —      | 0 V            | —         | Signal GROUND level.  |
| 17     | —      | CHASSIS GROUND | —         | Connected to printer chassis, not to signal ground.                             |
| 18     | —      | NC             | —         | Not used.   |
| 19-30  | —      | GND            | —         | Signal GROUND for pins 1-12.  |
| 31     | —      | INIT           | in        | LOW pulse of less than 50 microseconds causes printer to be initialized.        |
| 32     | —      | ERROR          | out       | This is LOW when there is no paper, printer is OFF LINE, or an error occurs.    |
| 33     | —      | GND            | —         | Signal GROUND level.  |
| 34     | —      | ND             | —         | Not used.   |
| 35     | —      | —              | —         | Connected to + 5V via 3.3 kOhms.  |
| 36     | —      | SLCT IN        | in        | DC1 and DC3 codes can only enable and disable printer when this signal is HIGH. |



---

## The Serial Interface

The LQ-2500 standard serial interface is an RS-232C interface with the following characteristics:

### Synchronization

Asynchronous

### Data format

1 start bit

**data** word length: 8 bits

odd, even or no parity

1 stop bit

### Baud rate

300, 600, 1200, 4800, 9600, 19,200 bps

### Signal level

mark (1) -3 V to -27 V

space(O) +3 V to +27 V

### Handshaking

Handshaking by DTR signal or X-on/X-off. The DTR signal changes to “mark”-meaning the printer is not ready to receive data-when the number of bytes free in the input buffer goes down to 256. The signal changes to ‘space’-meaning that the printer is now ready-when the number of bytes free in the input buffer rises to 528.

The arrangement of pins is shown in the figure below:

---

*Figure H-2.*  
*Serial interface*

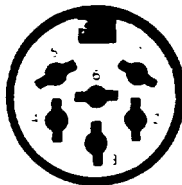

---

### Error handling

All errors are ignored.

### Connector

6-pin DIN connector.

In Table H-2, the direction of signals is given relative to the printer.

*Table H-2. Send interface*

| Pin number | Signal                   | Signal direction | Description   |
|------------|--------------------------|------------------|---|
| 1          | TXD                      | out              | Transmits data for X-on/X-off   |
| 2          | DTR<br>(Reverse channel) | out              | Whether or not the printer is ready to receive data. "MARK" level Indicates printer is not ready to receive data. |
| 3          | RXD                      | in               | Receives data   |
| 4          | NC                       |                  | Not used  |
| 5          | <b>/SG</b>               | -                | Signal around level   |
| 6          | FG                       | - -              | ( Printer chassis ground  |

---

# Glossary

Note that these definitions apply specifically to printers. If a word is italicized, see that topic for more information.

## **Application program**

Software designed to perform a specific task, such as word processing **or** accounting.

## **ASCII**

American Standard Code for information Interchange. A standardized coding system for letters and symbols, it is used by nearly all manufacturers of computers, printers, and software.

## **Auto line feed**

Most computers send automatic line feeds at the end of every line. If all of the lines are printing on top of each other, refer to the Auto Line Feed section under \*Change Defaults in Chapter 2.

## **Automatic sheet feeder**

A **device** that automatically feeds single sheets of paper into a printer. Sometimes called a cut sheet feeder.

## **Baud rate**

A measure of the speed of data transmission. Usually equivalent to bits per second.

## **Bidirectional printing**

Printing in which the print head goes from left to right only on every other line. On the other lines it goes from right to left. This increases the speed of the printing because the head prints in both directions.

## **Binary**

*See Number systems.*

## **Bit**

A binary digit (0 or 1). The smallest unit used by a printer or computer. *See also Number systems.*

## *Carriage return*

A control **code** that returns the print position to the left margin. In bidirectional printing the print head may not actually move to the left margin.

---

**CG table**

The LQ-2500 has three Character Generator (CC) **tables**: Italic, Graphic, and Download. These tables contain the characters printed by the printer. See Chapter 5 for more information on the tables; see Appendix B for printouts of the tables themselves.

**Compressed**

*See Condensed.*

**Condensed**

A print width approximately 60% of the width of standard characters. For example, condensed 10 pitch has 17 characters per inch (cpi). (Formerly called compressed.)

**configure**

To prepare a piece of equipment or a program so that it will work with other equipment.

**Continuous-feed paper**

This paper has pin-feed holes in half-inch tear-off strips on each side and is perforated between pages. After printing you remove the tear-off strips and separate the pages. Also called fan-fold paper.

**Control code**

The ASCII standard includes codes for printable characters and 33 other codes, which are called control codes. These are the **codes** for such functions as sounding the beeper and performing a carriage return.

**Current settings**

Whenever the LQ-2500 prints, it uses a group of settings called the current settings. These include all the settings shown in Table 2-1 in Chapter 2. All these settings can be changed with SelecType.

**Cut sheet feeder**

*See Automatic sheet feeder.*

**Data dump**

A trouble-shooting feature. When the printer is in the data dump mode, each **code** that it receives is printed in hexadecimal notation. Sometimes called hex dump.

**Decimal**

*See Number systems.*

---

**Default**

Values or settings that take effect when the equipment is turned on, reset, or initialized. For example, 10 pitch is usually the default width, which means that the printer prints in 10 pitch unless it is told to use another width. On the LQ-2500, the SelecType Default Settings are used to set the default values.

**Default bin**

When using a double-bin automatic sheet feeder, this is the bin that is automatically chosen when printing begins. As indicated on Table 2-1, this setting is available only when the automatic sheet feeder setting is selected with SelecType.

**Default macro**

The default macro is the macro you select to be in effect when you turn the power on. The default macro is set with SelecType according to Table 2-2.

**DIP switches**

Small switches in a printer that control various printer functions. DIP stands for Dual In-line Package. On the LQ-2500, these switches have been replaced by SelecType.

**Dot graphics**

A graphic design formed by patterns of dots.

**Dot matrix**

A method of printing in which letters and symbols are formed by patterns of individual dots.

**Double-strike**

A print mode in which each character is printed twice, with the second slightly below the first.

**Double-width**

A print width in which each character is twice as wide as normal characters. (Double-width was formerly known as expanded.)

**Draft**

One of two print qualities available on the LQ-2500. Draft uses a minimum number of dots per character for high-speed printing: Letter Quality reduces the print speed to increase the print quality

---

**Elite**

*See 12 pitch.*

**Emphasized**

A printing mode in which each dot is printed twice, with the second dot slightly to the right of the first.

**Escape (ESC)**

A special control code used to begin most printer commands.

**ESUP**

Abbreviation for Epson Standard Code for Printers, a set of commands developed by Epson and supported by almost all application software for personal computers.

**Expanded**

*See Double-width.*

**15 pitch**

A pitch with fifteen characters per inch.

**Font**

A font is a style of type designated by a family name. The LQ-2500 has five built-in fonts: Roman, Sans Serif, Courier, Prestige, and Script. All five are selectable with the DRAFT or LQ buttons, or with SelecType.

**Fom**

In printer terminology this term is usually equivalent to a page.

**Form feed**

A control code and a button that advances the paper to the top of the next page or form area.

**Form length**

A SelecType setting that allows you to set the length of the form you are printing on. The range is from 4 to 22 inches, in 1/2-inch increments.

**Graphic character set**

The Epson Graphic character set allows you to use all Epson commands, have access to graphic characters such as boxes, lines, etc., and use italics. See Chapter 5.

---

**Hexadecimal (hex)**

*See Number systems.*

**Half speed**

This is a SelectType setting that slows down print speed for quieter operation.

**Hex dump**

*See Data dump.*

**Initialize**

Return the printer to its *defaults*.

**Interface**

The connection between the computer and the printer. A serial interface transmits data one bit at a time and a parallel interface transmits data one character or code at a time.

**Italic**

A typestyle in which the characters slant. *This sentence is italicized.*

**Left margin**

A SelectType setting that lets you set the column position where printing will begin. The range is from 1 to 80. The left margin setting must be less than the right column setting.

**Letter Quality (LQ)**

One of two methods of printing on the LQ-2500. Letter Quality reduces the print speed and increases the number of dots per character to increase the print quality. Draft uses a minimum number of dots per character for high-speed printing.

**Line feed**

A control code or button that advances the paper one line space.

**Line space**

The distance that the paper moves between lines. Standard line spacing is 1/6th of an inch, but it can be changed by printer commands.

**Liquid Crystal Display (LCD)**

The display panel on the LQ-2500 that shows SelectType messages, print quality selection, and printer status.

---

## Macro

A group of settings that can be saved and recalled by pressing a sequence of buttons. SelecType has four macros.

## Main menu

in SelecType, the main menu displays the four modes: **\*Load Macro**, **\*Change Macro**, **\*Change Defaults**, and **\*Print Out Settings**.

## Number systems

Three number systems are commonly used with printers:

**Decimal** is base 10 and **uses** the digits 0, 1, 2, 3, 4, 5, 6, 7, 8, and 9. (This is the most familiar system.)

**Hexadecimal** (hex) is base 16 and uses the digits 0, 1, 2, 3, 4, 5, 6, 7, 8, 9, A, B, C, D, E, and F. This is frequently used **by** programmers. Any decimal number between 0 and 255 can be expressed by a two-digit hex number.

**Binary** is base 2 and uses only the digits 0 and 1. All information in computer systems is handled in binary form representing electrical signals that are **ON or OFF**. A binary digit is often called a bit; any decimal number between 0 and 255 can be expressed by an eight-bit binary number.

## One-inch skip

A SelecType setting that causes the printer to stop printing, skip over a perforation in continuous-feed paper, then resume printing again. Most application programs handle this **task**, but it may be useful when listing programs.

## Paper bail

The part of the printer that holds the paper against the platen.

## Paper-out sensor

A small switch behind the platen that sends a signal when it is not in contact with paper.

## Parallel interface

An interface is the connection between the computer and the printer. There are two types: a parallel interface transmits data one character or **code** at a time, and a serial interface transmits data one **bit at a** time.



---

## Parity

Parity is a method for a computer and printer to check the reliability of data transmission.

## Pica

*See IO pitch.*

## Pitch

Indicates the number of characters per inch (cpi). For example, 10 pitch printing is 10 cpi.

## Platen

The black roller that provides a backing for the printing.

## Print direction

The LQ-2500 has two print direction settings, bidirectional, (Bi-D), and unidirectional (Uni-D). Generally bidirectional is used for text printing; it's the faster of the two directions. Unidirectional is used mostly for graphics, because it permits better alignment, although it prints slower.

## Print quality

The LQ-2500 has two types of print quality: draft and Letter Quality. Draft is for high-speed, draft quality jobs; Letter Quality is for final, polished correspondence.

## Proportional printing

Printing in which the width of the character varies from character to character. Therefore, a capital W, for example, receives much more space than a lowercase i.

## RAM

Random Access Memory The portion of the printers memory used as a buffer and for storing user-defined characters. All data stored in RAM is lost when the printer is turned off.

## Reset

Returning a printer to its *defaults*, with either a command, an INIT signal, or by turning the printer off and on.

## Right margin

A SelecType setting that lets you set the column position where you want the last character printed. The range is from 1 to 136. The right margin setting must be greater than the left column setting.

---

**ROM**

Read Only Memory. The portion of the printers memory that is permanent. The printer uses the information in the ROM, but the information cannot be changed.

**SLCT-IN**

For most application programs, and most uses, the SLCT-IN setting should remain Valid. This means that the printer cannot be deselected or reselected by the DC1 or DC3 control codes (see Appendix A for further explanation). If its set to Invalid, the printer can be deselected or reselected by DC1 or DC3.

**Self test**

A method of checking the operation of the printer. When the self test is turned on, the printer prints the characters that are stored in its ROM.

**Serial interface**

An interface is the connection between the computer and the printer. There are two types: a serial interface transmits data one bit at a time. and a parallel interface transmits data one character or code at a time.

**Subscript mode**

Prints characters about twothirds of the normal height in the lower part of the character space.

**Superscript mode**

Prints characters about twothirds of the normal height in the upper part of the character space.

**Top of form**

A setting that enables the printer to begin printing in the proper place and to advance the paper correctly when it receives a form feed.

**Tractor**

The part of the printer that moves continuous-feed paper through the printer.

**10 pitch**

A pitch with 10 characters per inch. Also called pica. This is often the standard or default character width.

**12 pitch**

A pitch with 12 characters per inch. Also called elite.

---

**Unidirectional printing**

Printing in one direction only. Allows more precise vertical alignment than *bidirectional printing*. Often used for printing graphics.

**User-defined characters**

Characters defined and stored in the printer by the user. Also called download characters.

---

# Index

Command descriptions and definitions of terms are not indexed here. For page references for specific commands, see pages A-4 - 6 or the Quick Reference Card. For definitions of terms, see the Glossary.

## A

American Standard Code for Information Interchange, 4-2 - 3  
Application programs, 4-1 - 12  
    setting up, 4-1 - 4  
ASCII. 4-2 - 3  
    chart, B-1 -2  
Auto line feed, 2-15  
Automatic sheet feeder, 3-1

## B

Bail. paper, 1-2, 1-1 2  
BASIC, 4-11 - 12  
Baud rate, 2-14  
Beeper. D-3  
Bit image graphics. See Graphics  
Buffer. F-1-2, G-1  
Buttons 1-6 - 9  
    SelecType, 2-1 - 2  
Buzzer. See Beeper

## C

Carbon copies, 3-1, 3-8  
Centronics, 1-15  
CG (Character Generator) tables,  
    4-10, 5-7-9  
    graphic tables, 2-1 5-7, B-6-7  
    download. 5-8  
    italic tables, 5-8, B-5  
Change Macro mode, 2-3 - 4,  
    2-8- 12  
    save macro, 2-1 1 - 12  
Change Defaults mode. 2-3, 2-8  
Character widths, 5-1 - 6

Choosing a place for printer, 1-3  
Cleaning, D-7 - 8  
Color option, 1-3, 5-9  
Commands, A-4 - 35  
    by function, A-7 - 35  
    in numerical order, A-4-6  
Commercial programs, 4-1 - 12, 6-1  
    setting up, 4 -1-12  
Computer-printer communications,  
    4-2-3  
Computer-printer connections,  
    1-15- 16  
Condensed printing, 5-3  
Control codes. 4-2  
Control keys, A-3  
Control panel. 1-6-9, 2-2  
    current settings, 2-6. 2-8- 10  
    changing, 2-10-12  
Cut sheet feeder. See Automatic  
    sheet feeder

## D

Data dump. See Hex dump  
Decimal numbering system, 4-3  
    sending commands. 4-11  
Default settings, 1-6, 2-13, E-1 -2  
    options, 2-13  
Default macro. 2-4, 2-13, 2-14  
    changing, 2-15-17  
Defaults, preset. 2-13  
DIP switches. 1-7, 2-1  
Double-strike. 3-6  
Double-width printing, 5-5 - 6  
Draft, 1-8. C-3  
Dust cover. 1-1

---

## E

Edge tab, 1-9- 10  
Elite. See 12 pitch  
Emphasized printing, 5-6  
ESUP module, 5-8  
ESCape codes, 4-2 - 3  
    See also Commands

## F

15 pitch, 5-4 - 5  
Font cartridges, 5-3  
Fonts, 2-1, 2-10, 5-1 -3, C-1 -2  
    selection, 1-8  
    self test, 1-13- 14  
Foreign language characters. See  
    international characters  
FORM FEED, 1-8  
Forms, multi-part, 3-1

## G

Graphics, 6-1-11  
    commercial programs, 4 -10.  
    6-1  
    troubleshooting, D-4

## H

Hex dump mode, D-5 - 6  
Hexadecimal system, 4-3  
    sending commands, 4-11

## I

IBM PC BASIC, 6-9  
IBM and compatible solutions, D-7  
Icons, 1-1 1  
Identity modules, 5-3  
IEEE interface, F-2

Indicator lights, 1-6 - 9, 2-2  
Initialization, 1-6, E-1 -2  
installing software, 4-3-12  
Interfaces,  
    choosing, 1-15- 16  
    IEEE, F-2  
    optional, F-1 - 8  
    parallel, 2-14, H-1 -2  
    serial, 2-14, H-3-4  
    specifications, H-1 - 4

International characters, 5-8 - 9  
    character tables, B-3

Italics, 4 -11-12

Italic character set, 5-1

## K

Knob, paper feed, 1-2

## L

Labels, 3-7  
Letter Quality 1-8  
Levers, 1-11-12  
Lights, 1-6-9, 2-2  
LINE FEED, 1-1-8  
Liquid Crystal Display (LCD), 1-6,  
    2-1  
Load Macro mode, 2-3 - 7  
Loading paper. See Paper

## M

Macros, 2- 1, 2-4 - 5  
    default, 1-13, 2-4  
    entering, 2-2  
    preset, 2-1, 2-4 -5  
    save, 2-11-12  
Maintenance, D-7  
Master Select, C-3 - 4  
Menu, SelecType, 2-3  
Microsoft BASIC, 4 -11  
Moving the printer, D-8

---

## N

Numbering systems, 4-3

## O

OFF LINE, 1-7 - 8

ON LUE, 1-7-8

light, 1-7, 1-9

Optional interfaces, F-1 - 8

## P

Panel, control, 1-6 - 9

Panel, SelecType, 2-1 - 2

Paper,

choosing, 3-1

feeding, 1-8

length, 2-8

loading continuous feed, 3-2 - 7

loading single sheets, 1-10 - 12, 3-1

reloading, 3-2

size, 3-1

thickness, 3-1

width, 3-1

Paper bail, 1-2, 1-12

Paper feed knob, 1-2

Paper guide,

continuous feed, 3-5

single sheets, 1-9 - 10

Paper loading icons, 1-11

PAPER OUT light, 1-6, 1-11

Paper rest, 3-2

Paper roll holder, 3-1

Paper support, 3-2

Paper thickness lever, 3-8

Parallel interface, 1-15, 2-14, H-1 -2

Parity 2-14

Pica. See 10 pitch

Pitch, 5-4-5

designated, 5-4-5

POWER light, 1-6 - 1-7, 1-9

Print features, 5-1 -9

Print head, 6-2, D-8

protector, 1-2

Print Out Settings mode, 2-3 -4, 2-18- 19

Print quality 1-8, 5-1 -2, 2-10

Printer commands, 4-6 - 7

embedding, 4-7

Printer

driver, 4-4

maintenance, D-7

options, 2-8

selection, 4-1 - 2

settings, 2-8

transporting, D-8

Programming languages, 4-8, 4-1 1

Proportional spacing, 5-4 - 5

width table, B-8- 11

## R

READY light, 1-7, 1-9

Ribbons,

black. 1-5. 3-9

color, 1-3, 5-9

installing, 1-3 - 5

life, G-2

## S

SelecType, 2-1 - 19

entering, 1-7 - 9

menu, 2-3

options, 2-8

panel, 2-1 -2

settings, 2-8

Self test, 1-13- 15

Serial interface, 1-16, H-3-1

cables, 1-16

optional, F-2 - 3

SelecTy-pe, 2-14

troubleshooting, D-5

Setting up, 1-1 - 18

---

Slot-in, 2-15  
Specifications,  
    interface, H-1 -4  
    technical, G1 -3  
Spreadsheets, 4-7 - 9  
Sprockets. See Paper, continuous  
    feed  
Subscripts, 5-7  
Superscripts, 5-7

## T

Ten pitch, 5-4 -5  
Top of form, 3-6  
Tractor, 3-2 - 5  
Troubleshooting, D-5 - 5  
    general, D-1 - 3  
    graphics, D-4  
    IBM BASIC, D-7  
    IBM and compatibles. D-7  
    serial interface, D-5  
Typestyle summary C-1 - 4  
12 pitch, 5-4 - 5

## U

Underlining, 5-4  
User-defined characters, 6-12 - 20

## W

WIDTH statement, 6-9  
Word processors, 4-4-6

The following control codes are listed briefly for quick reference. For a more detailed explanation, see the page reference in Appendix A. Variables are not included in this quick reference due to their complexity. For those codes that contain variables, such as ESC Q n for setting the right margin, refer to Appendix A.

**Printer Operation/Data Control**

| Code   | Dec | Hex | Function                              | Pg   |
|--------|-----|-----|---------------------------------------|------|
| ESC @  | 64  | 40  | Initialize Printer                    | A-7  |
| DC1    | 17  | 11  | Select Printer                        | A-7  |
| DC3    | 19  | 13  | Deselect Printer                      | A-8  |
| DEL    | 127 | 7F  | Delete Character                      | A-8  |
| ESC #  | 115 | 73  | Turn Half-speed Mode On/Off           | A-8  |
| ESC (  | 60  | 3C  | Select Unidirectional Mode (one line) | A-9  |
| ESC U  | 85  | 55  | Turn Unidirectional Mode On/Off       | A-9  |
| ESC EM | 25  | 19  | Turn Automatic Sheet Feeder On/Off    | A-10 |
| ESC =  | 61  | 3D  | Set MSB to 0                          | A-10 |
| ESC )  | 62  | 3E  | Set MSB to 1                          | A-11 |
| ESC #  | 35  | 23  | Cancel MSB Control                    | A-11 |
| BEL    | 7   | 07  | Beeper                                | A-11 |
| CR     | 13  | 0D  | Carriage Return                       | A-12 |
| CAN    | 24  | 18  | Cancel Line                           | A-12 |

**Vertical Motion/Horizontal Motion**

|         |     |    |                                  |      |
|---------|-----|----|----------------------------------|------|
| FF      | 12  | 0C | Form Feed                        | A-12 |
| ESC C   | 67  | 43 | Select Page Length in Lines      | A-13 |
| ESC C 0 | 67  | 43 | Select Page Length in Inches     | A-13 |
| ESC N   | 78  | 4E | Select Skip-over-perforation     | A-13 |
| ESC O   | 79  | 4F | Cancel Skip-over-perforation     | A-14 |
| LF      | 10  | 0A | Line Feed                        | A-14 |
| ESC 0   | 48  | 30 | Select 1/8-inch Line Spacing     | A-14 |
| ESC 2   | 50  | 32 | Select 1/6-inch Line Spacing     | A-15 |
| ESC 3   | 51  | 33 | Select n/180-inch Line Spacing   | A-15 |
| ESC A   | 65  | 41 | Select n/60-inch Line Spacing    | A-15 |
| ESC J   | 74  | 4A | Perform n/180-inch Line Feed     | A-16 |
| VT      | 11  | 0B | Tab Vertically                   | A-16 |
| ESC B   | 66  | 42 | Select Vertical Tabs             | A-16 |
| ESC b   | 98  | 62 | Select Vertical Tabs in Channels | A-17 |
| ESC /   | 47  | 2F | Select Vertical Tab Channel      | A-17 |
| ESC I   | 108 | 6C | Set Left Margin                  | A-17 |
| ESC Q   | 81  | 51 | Set Right Margin                 | A-18 |
| BS      | 8   | 08 | Backspace                        | A-18 |
| ESC \$  | 36  | 24 | Select Absolute Print Position   | A-19 |
| ESC \   | 92  | 5C | Set Relative Position            | A-19 |
| HT      | 9   | 09 | Tab Horizontally                 | A-20 |
| ESC D   | 68  | 44 | Set Horizontal Tabs              | A-20 |

**Overall Printing Style/Print Size**

| Code   | Dec | Hex | Function                            | Pg   |
|--------|-----|-----|-------------------------------------|------|
| ESC x  | 120 | 78  | Select Letter Quality or Draft      | A-21 |
| ESC k  | 107 | 6B  | Select Typestyle Family             | A-21 |
| ESC r  | 114 | 72  | Select Printing Color               | A-22 |
| ESC !  | 33  | 21  | Master Select                       | A-22 |
| ESC P  | 80  | 50  | Select 10 Pitch                     | A-23 |
| ESC M  | 77  | 4D  | Select 12 Pitch                     | A-23 |
| ESC g  | 103 | 67  | Select 15 Pitch                     | A-23 |
| ESC p  | 112 | 70  | Turn Proportional Mode On/Off       | A-24 |
| SI     | 15  | 0F  | Select Condensed Mode               | A-24 |
| ESC SI | 15  | 0F  | Select Condensed Mode               | A-24 |
| DC2    | 18  | 12  | Cancel Condensed Mode               | A-25 |
| SO     | 14  | 0E  | Select Double-width Mode (one line) | A-25 |
| ESC SO | 14  | 0E  | Select Double-width Mode (one line) | A-25 |
| DC4    | 20  | 14  | Cancel Double-width Mode (one line) | A-26 |
| ESC W  | 87  | 57  | Turn Double-width Mode On/Off       | A-26 |

**Print Enhancement/Word Processing**

|             |    |    |                                     |      |
|-------------|----|----|-------------------------------------|------|
| ESC E       | 69 | 45 | Select Emphasized Mode              | A-26 |
| ESC F       | 70 | 46 | Cancel Emphasized Mode              | A-27 |
| ESC G       | 71 | 47 | Select Double-strike Mode           | A-27 |
| ESC H       | 72 | 48 | Cancel Double-strike Mode           | A-27 |
| ESC S0      | 83 | 53 | Select Superscript Mode             | A-28 |
| ESC S1      | 83 | 53 | Select Subscript Mode               | A-28 |
| ESC T       | 84 | 54 | Cancel Superscript/Subscript        | A-28 |
| ESC _       | 45 | 2D | Turn Underlining On/Off             | A-29 |
| ESC a       | 97 | 61 | Select Letter Quality Justification | A-29 |
| ESC (space) | 32 | 20 | Select Intercharacter Space         | A-30 |

**Character Tables**

|       |     |    |                                       |      |
|-------|-----|----|---------------------------------------|------|
| ESC I | 116 | 74 | Select Character Table                | A-30 |
| ESC 4 | 52  | 34 | Select Italic Mode                    | A-31 |
| ESC 5 | 53  | 35 | Cancel Italic Mode                    | A-31 |
| ESC R | 82  | 52 | Select an International Character Set | A-31 |

**User-defined Characters/Graphics**

|       |    |    |   |      |
|-------|----|----|---|------|
| ESC & | 38 | 26 | Define User-defined Characters            | A-32 |
| ESC : | 58 | 3A | Copy ROM into RAM                         | A-32 |
| ESC % | 37 | 25 | Select User-defined Set                   | A-32 |
| ESC 6 | 54 | 36 | Enable Printable Characters               | A-33 |
| ESC 7 | 55 | 37 | Enable Upper Control Codes                | A-33 |
| ESC K | 75 | 4B | Select Single-density Graphics Mode       | A-33 |
| ESC L | 76 | 4C | Select Double-density Graphics Mode       | A-34 |
| ESC Y | 89 | 59 | Select High-speed Double-density Graphics | A-34 |
| ESC Z | 90 | 5A | Select Quadruple-density Graphics Mode    | A-34 |
| ESC * | 42 | 2A | Select Graphics Mode                      | A-34 |
| ESC ? | 63 | 3F | Reassign Graphics Mode                    | A-35 |

| Dec | Hex | Abbrev | Control Key | Dec | Hex | Char |
|-----|-----|--------|-------------|-----|-----|------|
| 0   | 00  | (NL)   | Control-@   | 33  | 21  | !    |
| 1   | 01  | (SOH)  | Control-A   | 34  | 22  | "    |
| 2   | 02  | (STX)  | Control-B   | 35  | 23  | #    |
| 3   | 03  | (ETX)  | Control-C   | 36  | 24  | \$   |
| 4   | 04  | (EOT)  | Control-D   | 37  | 25  | %    |
| 5   | 05  | (ENQ)  | Control-E   | 38  | 26  | &    |
| 6   | 06  | (ACK)  | Control-F   | 39  | 27  | '    |
| 7   | 07  | (BEL)  | Control-G   | 40  | 28  | (    |
| 8   | 08  | (BS)   | Control-H   | 41  | 29  | )    |
| 9   | 09  | (HT)   | Control-I   | 42  | 2A  | *    |
| 10  | 0A  | (LF)   | Control-J   | 43  | 2B  | +    |
| 11  | 0B  | (VT)   | Control-K   | 44  | 2C  | ,    |
| 12  | 0C  | (FF)   | Control-L   | 45  | 2D  | ;    |
| 13  | 0D  | (CR)   | Control-M   | 46  | 2E  | =    |
| 14  | 0E  | (SO)   | Control-N   | 47  | 2F  | >    |
| 15  | 0F  | (SI)   | Control-O   | 48  | 30  | @    |
| 16  | 10  | (DLE)  | Control-P   | 49  | 31  | A    |
| 17  | 11  | (DC1)  | Control-Q   | 50  | 32  | B    |
| 18  | 12  | (DC2)  | Control-R   | 51  | 33  | C    |
| 19  | 13  | (DC3)  | Control-S   | 52  | 34  | D    |
| 20  | 14  | (DC4)  | Control-T   | 53  | 35  | E    |
| 21  | 15  | (NAK)  | Control-U   | 54  | 36  | F    |
| 22  | 16  | (SYN)  | Control-V   | 55  | 37  | G    |
| 23  | 17  | (ETB)  | Control-W   | 56  | 38  | H    |
| 24  | 18  | (CAN)  | Control-X   | 57  | 39  | I    |
| 25  | 19  | (EM)   | Control-Y   | 58  | 3A  | J    |
| 26  | 1A  | (SUB)  | Control-Z   | 59  | 3B  | [    |
| 27  | 1B  | (ESC)  | Control-{   | 60  | 3C  | \    |
|     |     |        |             | 61  | 3D  | ]    |
|     |     |        |             | 62  | 3E  | ^    |
|     |     |        |             | 63  | 3F  | _    |
|     |     |        |             | 64  | 40  | @    |
|     |     |        |             | 65  | 41  | A    |
|     |     |        |             | 66  | 42  | B    |

| Dec | Hex | char | Dec | Hex | Char | Dec | Hex | Char |
|-----|-----|------|-----|-----|------|-----|-----|------|
| 67  | 43  | C    | 87  | 57  | W    | 107 | 6B  | k    |
| 68  | 44  | D    | 88  | 58  | X    | 108 | 6C  | l    |
| 69  | 45  | E    | 89  | 59  | Y    | 109 | 6D  | m    |
| 70  | 46  | F    | 90  | 5A  | Z    | 110 | 6E  | n    |
| 71  | 47  | G    | 91  | 5B  | [    | 111 | 6F  | o    |
| 72  | 48  | H    | 92  | 5C  | \    | 112 | 70  | p    |
| 73  | 49  | I    | 93  | 5D  | ]    | 113 | 71  | q    |
| 74  | 4A  | J    | 94  | 5E  | ^    | 114 | 72  | r    |
| 75  | 4B  | K    | 95  | 5F  | _    | 115 | 73  | s    |
| 76  | 4C  | L    | 96  | 60  | —    | 116 | 74  | t    |
| 77  | 4D  | M    | 97  | 61  | a    | 117 | 75  | u    |
| 78  | 4E  | N    | 98  | 62  | b    | 118 | 76  | v    |
| 79  | 4F  | O    | 99  | 63  | c    | 119 | 77  | w    |
| 80  | 50  | P    | 100 | 64  | d    | 120 | 78  | x    |
| 81  | 51  | Q    | 101 | 65  | e    | 121 | 79  | y    |
| 82  | 52  | R    | 102 | 66  | f    | 122 | 7A  | z    |
| 83  | 53  | S    | 103 | 67  | g    | 123 | 7B  | {    |
| 84  | 54  | T    | 104 | 68  | h    | 124 | 7C  |      |
| 85  | 55  | U    | 105 | 69  | i    | 125 | 7D  | }    |
| 86  | 56  | V    | 106 | 6A  | j    | 126 | 7E  | ~    |